

KESLA 2009L, 2009LT**Sisällysluettelo \ Innehållsförteckning \ Contents \ Inhaltsverzeichnis**

Pääkoonpano \ Sammansättning \ Final assembly \ Zusammensetzung	1
Käantölaite \ Vridanordning \ Slew mechanism \ Schwenkwerk	3
Tukijalkavarustus \ Stödbensutrustning \ Stabilizers \ Stützfußausrüstung	5
Nostopuomi \ Lyftbom \ Main lifting boom \ Hubarm	9
Nostopuomi hyttivarustus \ Lyftbom hytt utrustning \ Main lifting boom cabin assy \ Hubarm kabine Besatzung	11
Siirtopuomisto \ Vipparm \ Outer boom \ Knickarm KESLA 2009L	13
Siirtopuomisto \ Vipparm \ Outer boom \ Knickarm KESLA 2009LT	16
Siirtopuomiston ketju \ Kedja \ Chain \ Kette kompl. \.3x4 (81)	19
Vetotanko varusteltuna \ Dragstång \ Inner link assy \ Mittleres Gelenk	21
Nostosylinteri varusteltuna \ Lyftcylinder utrustning \ Accessories for main lifting cylinder \ Ausrüstung für Hubzylinder	23
Nostosylinteri \ Lyftcylinder \ Main lifting cylinder \ Hubzylinder	25
Siirtosylinteri varusteltuna \ Vippcylinder utrustning \ Accessories for outer boom cylinder \ Ausrüstung für Knickarmzylinder	27
Siirtosylinteri \ Vippcylinder \ Outer boom cylinder \ Knickarmzylinder	29
Tukijalkojen levityssylinteri \ Spridningscylinder \ Spreading cylinder \ Ausshubzylinder für Stützfüsse	31
Jatkeen sylinteri \ Utskjutscylinder \ Extension cylinder \ Ausschubzylinder \ KESLA 2009LT	33
Tukijalan sylinteri \ Stödbenscylinder \ Stabilizer cylinder \ Stützfußcylinder	35
Riipuke varusteltuna \ Rotatorlänk \ Rotator link \ Rotatorgelenk	37
Painesuodatin \ Tryckfilter \ Pressure filter \ Druckfilter	39
Kiinnityspultit \ fastening bolts \ fästbults \ Aufspannbolzen \	41
Hallintalaitteet \ Styrningsanordning \ Control unit \ Bedienungsanordning	43→

90000315

NOSTURI

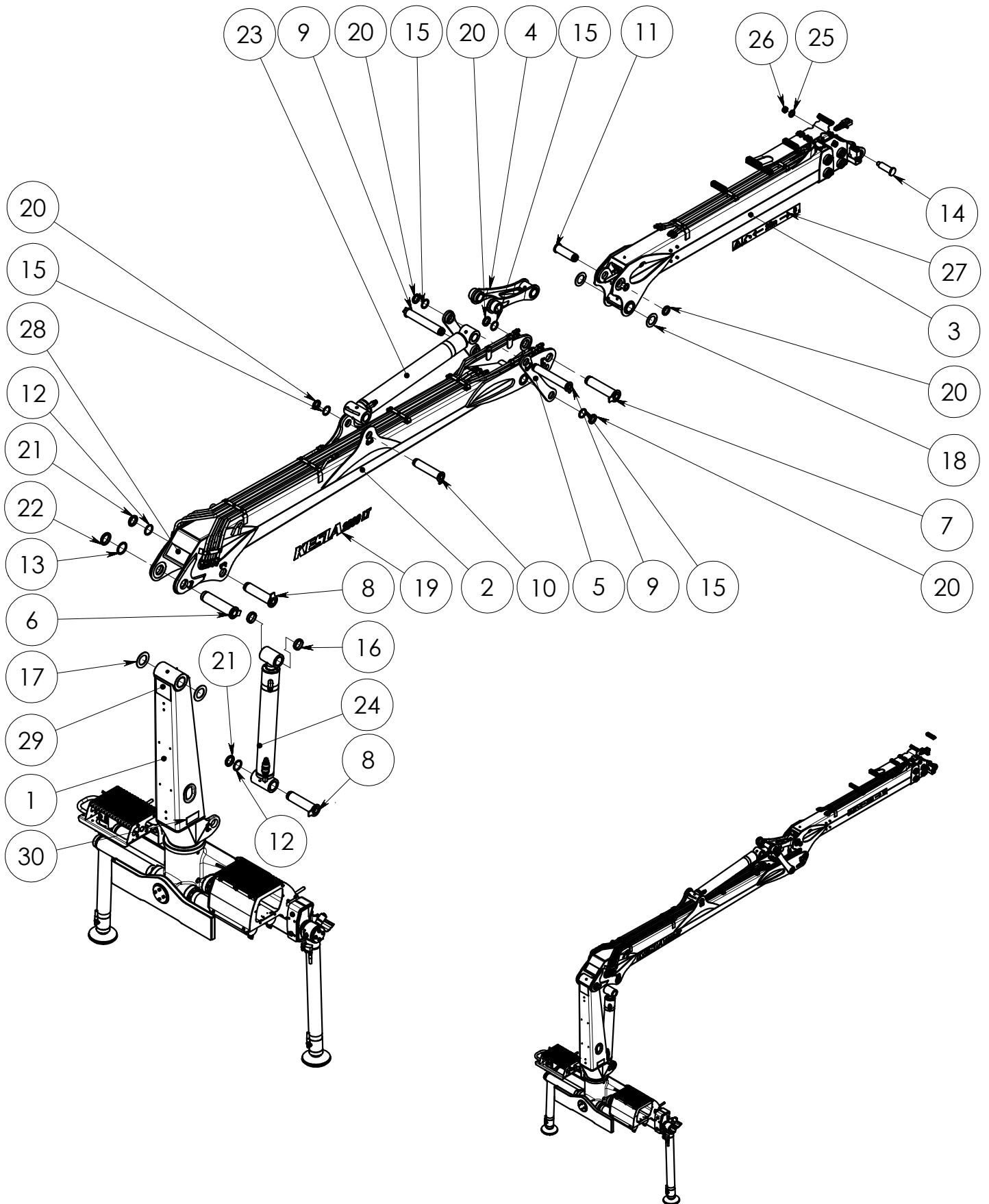



SPARE PART LIST

Item code	90000315	Revision	-
Title	NOSTURI	Date	22.11.2007
Specification	KESLA 2009LT		

Pos	Item code	Title	Specification	Dimensions	Pc	Amount	Unit	Nto Weight
1	90022495	JALKA FOT FOOT FUSS	TUKIJALKAVAR		1			899.75
2	90021987	NOSTOPUOMI LYFTBOM LIFT BOOM HUBARM	VAR		1			307.57
3	90021963	PUOMI BOM BOOM ARM	SIIRTOPUOMI 2-JATK		1			310.1
4	90017910	TANKO LÄNK LINK GELENK	VAR		1			19.26
5	90017907	TANKO LÄNK LINK GELENK	SVUTANKO HITS+KON		2			6.83
6	90015226	AKSELI AXEL AXLE ACHSE	80/M75-338		1			9.09
7	90020967	AKSELI AXEL AXLE ACHSE	70/M65X2-318		1			7.2
8	90015998	AKSELI AXEL AXLE ACHSE	70/M65X2-298		2			6.76
9	90017837	AKSELI AXEL AXLE ACHSE	60/M55X2 -387		2			6.77
10	90017846	AKSELI AXEL AXLE ACHSE	60/M55X2-293		1			5.12
11	90017848	AKSELI AXEL AXLE ACHSE	60/M55X2 -210		1			3.7
12	90016000	ALUSLEVY BRICKA WASHER UNTERLEGSCHHEIBE	85/71-6	150x75	2			0.08
13	90013697	ALUSLEVY BRICKA WASHER UNTERLEGSCHHEIBE	100/81-6	150x75	1			0.13
14	90013105	AKSELI AXEL AXLE ACHSE	45-164	L=167	1			1.94
15	90013698	ALUSLEVY BRICKA WASHER UNTERLEGSCHHEIBE	75/61-6	150x75	4			0.07
16	90016045	HOLKKI HYLSA SLEEVE ACHSHALTER	85/71-18	L=20	2			0.24
17	90010011	LAAKERI LAGER BEARING LAGER	130/80.5 - 5	142x142	2			0.05
18	90012607	LAAKERI LAGER BEARING LAGER	112/70.5-5	142x142	2			0.03
19	3281416	TARRA DEKAL DECAL AUFKLEBER	100X842 KESLA 2009LT		2			0.07
20	3020164	MUTTERI MUTTER NUT MUTTER	KM 11 NYLOC M55X2.0		5			0.17
21	3020157	MUTTERI MUTTER NUT MUTTER	KM 13 NYLOC M65X2.0		2			0.26
22	3020158	MUTTERI MUTTER NUT MUTTER	KM 15 NYLOC M75X2		1			0.35
23	90022183	SYLINTERI CYLINDER CYLINDER ZYLINDER	120X60X908 SIIRTOSYLINTERI 2009L		1			31.64
24	90022184	SYLINTERI CYLINDER CYLINDER ZYLINDER	120/70 X 800		1			31.05
25	90013106	ALUSLEVY BRICKA WASHER UNTERLEGSCHHEIBE	56/31-8	150x75	1			0.08
26	3020144	MUTTERI MUTTER NUT MUTTER	KM6 M30X1.5 ZN NYLOC		1			
27	3281135	TARRA DEKAL DECAL AUFKLEBER	VAARA-ALUE 25M		2			0.1
28	3281439	KILPI SKYLIT PLATE SCHILD	2009LT NOSTOARVOT		1			0.16
29	3280264	TARRA DEKAL DECAL AUFKLEBER	VARO JÄNNITTEISTÄ.		1			
30	3280201	KILPI SKYLIT PLATE SCHILD	TYPE PLATE CE		1			
31	3280231	TARRA DEKAL DECAL AUFKLEBER	OHJAUSKAAVIO 2-VIPU		1			
50	90022521	RUUVI SKRUV SCREW SCHRAUBE	SARJA M30X2-750		1			24.8

90022488

KÄÄNTÖLAITE

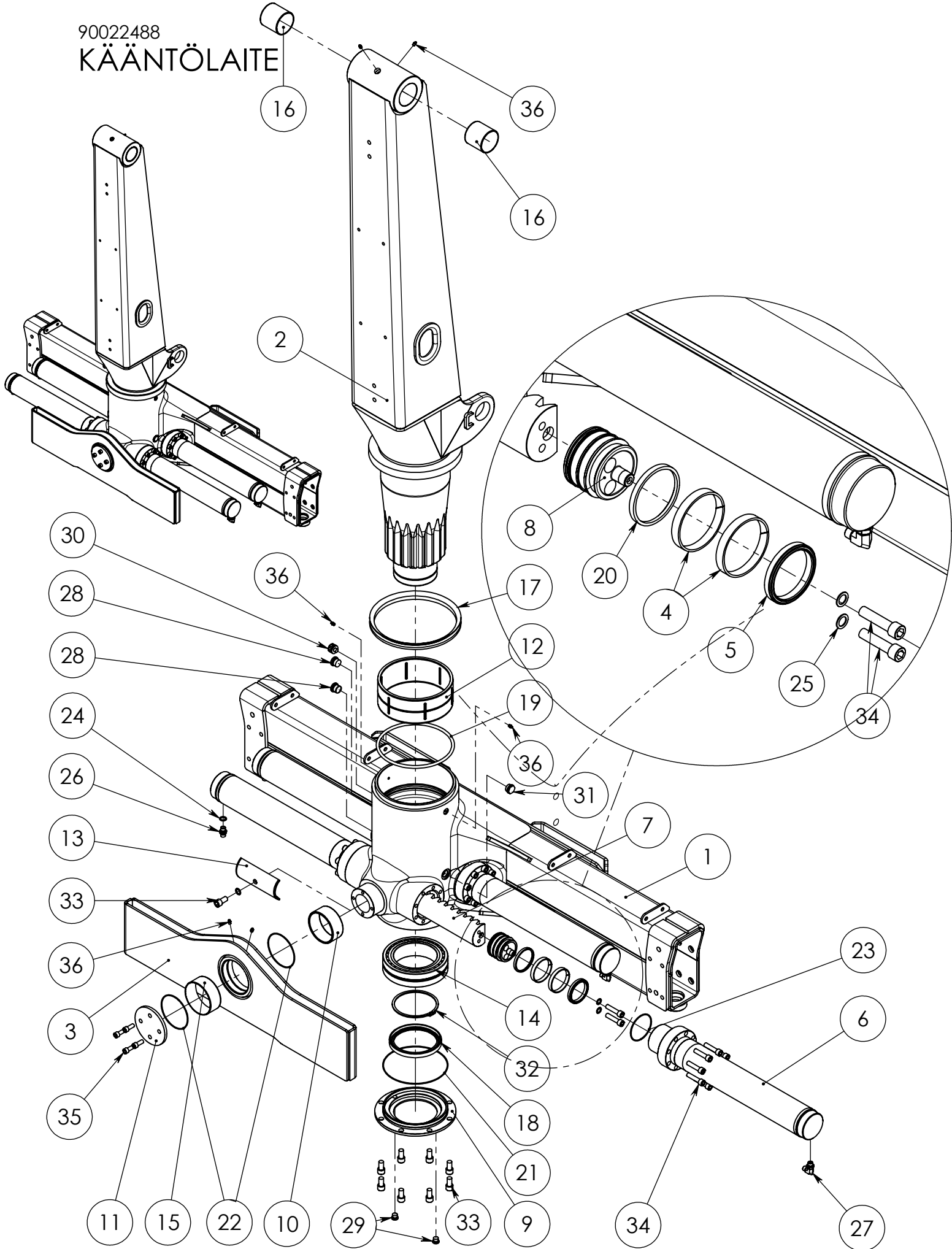



OSALUETTELO

Nimikenumero	90022488	Revisio	-
Nimitys	KAANTOLAITE	Päiväys	04.04.2008
Specifikaatio		Liitty	

Pos	Nimike n:o	Nimitys + Specifikaatio	Mitat	Kpl	Määrä	Yks	Nto paino	Huom
1	90022481	RUNKO HITS (U-TUKIJALKAPALKKI)		1			272.64	
2	90021856	PYLVÄS KONEISTUS		1			263.72	
3	90021823	PALKKI HITS+KON		1			34.47	
4	3110637	TIIVISTE E/PWR 90/84X13		8			0.08	
5	3110636	TIIVISTE B7 90/75X12 (F908		4			0.16	
6	90021819	SYLINTERI		4			17.00	
7	90021811	HÄMMÄSTANKO	L=850	2			22.25	
8	90021815	MÄNTÄ	L=95	4			2.35	
9	90021820	LAIPPA	286x286	1			4.09	
10	90020846	HOLKKI 120/110-50	L=53	1			0.70	
11	90020845	LAIPPA 145X90-10	145x145	1			1.25	
12	90012821	HOLKKI 260/240-100	L=102	1			0.88	
13	90016013	LAAKERI 97.6/85-189	L=191	2			0.13	
14	3100331	LAAKERI 23030CC/W33		1				
15	3100218	LAAKERI WB 802 12050		1			0.38	
16	3100187	LAAKERI WB 802 8080		2			0.41	
17	3110930	TIIVISTE VA-300		1			1.63	
18	3110565	TIIVISTE RST 150X180X15		1			0.50	
19	3110909	PYYHKIJÄ A1240X18		1				
20	3110638	TIIVISTE PPW 90/81.4X5.3		4			0.05	
21	3110771	TIIVISTE O 219.5X3.0 70 SH		1			0.04	
22	3110461	TIIVISTE O 124.5 X 3.0 SHORE 70		2			0.02	
23	3110639	TIIVISTE O 96X3.0 70 SHORE (F908/910)		4			0.02	
24	3110040	TIIVISTE USIT R-06 (R 3/8")		4			0.00	
25	3030080	TIIVISTE CU M14		8				
26	3090040	LIITIN 04000-06		2			0.06	
27	3090475	LIITIN 04500-26-06		2			0.12	
28	3090209	TULPPA HF-3/4"		2			0.08	
29	3090210	TULPPA HF-3/8"		2			0.03	
30	3091042	HUOHOTIN R1/4" SFV. 1/4-100 MB		1			0.11	
31	3090294	OSOITIN R 3/4" HFTX-20		1			0.01	
32	3060076	PIDÄTINRENGAS A 150X4; DIN 471		1			0.00	
33	3010700	RUUVI KKR M16 X 30 8.8 ZN DIN 912		10			0.00	
34	3010601	RUUVI KKR M14X60 12.9 DIN 912		40			0.00	
35	3010246	RUUVI KKR M12 X 30 8.8 ZN DIN 912		4			0.00	
36	3050003	RASVANIPPA M8X1,25 DIN 71412		6			0.00	



SPARE PART LIST

Item code	90022488	Revision	-
Title	KÄÄNTÖLAITE	Date	04.04.2008
Specification	23 kNm		

Pos	Item code	Title	Specification	Dimensions	Pc	Amount	Unit	Nto Weight
37	3110640	TIIVISTE TÄTNING SEAL DICHTUNG	90		1		sfj	

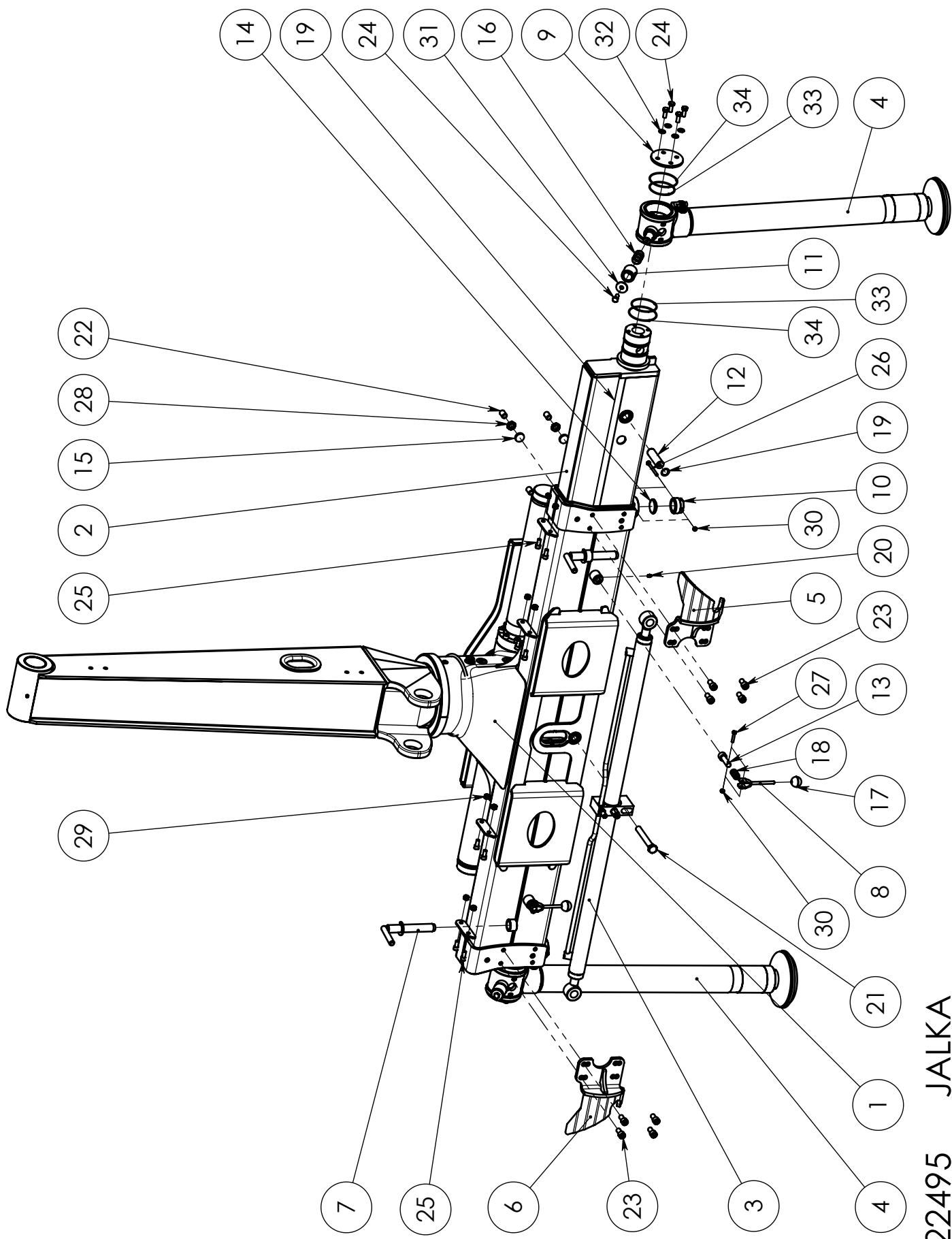

90022495 JALKA

VARAOSAT \ RESERVDLAR \ SPARE PARTS \ ERSATZTEIL

Item code	90022495	Revision	A
Title	FOOT	Date	15.04.2008
Specification	TUKIJALKAVAR		

Pos	Item code	Title	Specification	Pc	Nto Weight
1	90022488	SLEW MECHANNISM	23 kNm	1	672.75
2	90022477	ARM	HITS (U-TUKIJALKAPALKKI)	2	46.66
3	28812001	CYLINDER	50/30X2X600	1	8.11
4	28554001	CYLINDER	90/70X750	2	24.56
5	90021843	CABLE	OIKEA HITS	1	4.9
6	90021844	CABLE	VASEN HITS	1	4.9
7	90011249	AXLE	HITS	2	1.43
8	90012844	LEVER	10-120	2	0.16
9	90011250	FLANGE		2	0.73
10	90016090	FASTENER		2	0.35
11	90012841	SLEEVE	50/34-50	2	0.41
12	90013050	AXLE	30-102	2	0.57
13	90012843	SPINDLE	28/18-76	2	0.2
14	90020689	GLIDE PAD	40X55-7X5	2	0.03
15	90020807	GLIDE PAD		6	0.01
16	3100124	BEARING	PM 3020 DX	4	0.03
17	3120453	KNOB		2	0.25
18	3300533	SPRING	18/45/7.6/6.88 -1643 SF-TF3	2	0.02
19	3060019	SNAP RING	30 DIN 472	4	0
20	3050003	GREASE NIPPLE	M8X1,25 DIN 71412	2	0
21	3010049	SCREW	M20X150 8.8 ZN DIN 931	1	0
22	3010312	SCREW	M20X30 10.9 ZN DIN 913	6	0
23	3010700	SCREW	M16X30 8.8 ZN DIN 912	8	0
24	3010048	SCREW	M12X30 8.8 ZN DIN 933	10	0
25	3010239	SCREW	M12X25 8.8 ZN DIN 912	8	0
26	3010328	SCREW	M8X90 8.8 ZN DIN 931	2	0
27	3010441	SCREW	M8X40 8.8 ZN DIN 931	2	0
28	3020014	NUT	M20 ZN DIN 936	6	0
29	3020005	NUT	M12 ZN DIN 985	8	0.02
30	3020001	NUT	M8 ZN DIN 985	4	0.01
31	3030122	WASHER	M12 ZN DIN 440	2	0.04
32	3030047	WASHER	M12/13 ZN DIN 126	8	0.01
33	3110934	SEAL	O 94,5X3 70 SHORE	4	0.02
34	3110259	SEAL	104.5X3 90 SHORE	4	0.02
35	3010685	SCREW	M10X25 8.8 ZN DIN 912	1	0

90021987

NOSTOPUOMI

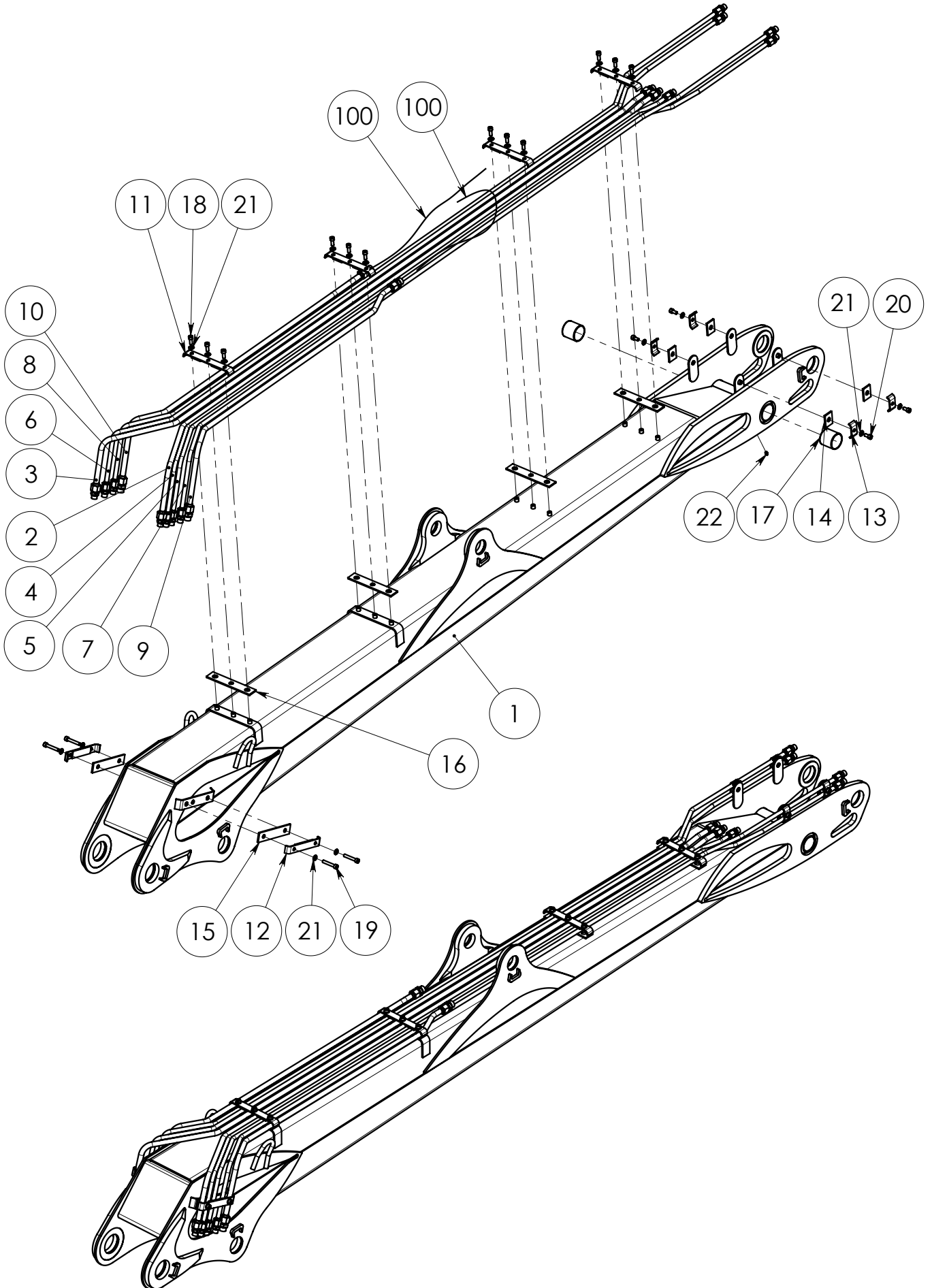



SPARE PART LIST

Item code	90021987	Revision	-
Title	NOSTOPUOMI	Date	19.12.2007
Specification	VAR		

Pos	Item code	Title	Specification	Dimensions	Pc	Amount	Unit	Nto Weight
1	90021886	PUOMI BOM BOOM ARM	KONESTUS		1			275
2	90021993	PUTKI RÖR PIPE ROHR	1 OIKEA KOK		1			4.42
3	90022003	PUTKI RÖR PIPE ROHR	1 VASEN KOK		1			4.42
4	90021996	PUTKI RÖR PIPE ROHR	2 OIKEA KOK		1			2.94
5	90021994	PUTKI RÖR PIPE ROHR	3 OIKEA KOK		1			3.3
6	90022004	PUTKI RÖR PIPE ROHR	3 VASEN KOK		1			3.3
7	90021997	PUTKI RÖR PIPE ROHR	4 OIKEA KOK		1			3.27
8	90022005	PUTKI RÖR PIPE ROHR	4 VASEN KOK		1			3.27
9	90021992	PUTKI RÖR PIPE ROHR	5 OIKEA KOK		1			2.57
10	90022006	PUTKI RÖR PIPE ROHR	5 VASEN KOK		1			2.57
11	90021956	KIINNIKE FÄSTE FASTENER BEFESTIGUNG	HITS		4			0.31
12	90021960	KIINNIKE FÄSTE FASTENER BEFESTIGUNG	HITS		2			0.3
13	90010442	KIINNIKE FÄSTE FASTENER BEFESTIGUNG	LT4X30-72	L=72	4			0.07
14	90010443	KUMI GUMMI RUBBER GUMMI		55x40	4			0.01
15	90021961	KUMI GUMMI RUBBER GUMMI		190x40	2			
16	90013489	KUMI GUMMI RUBBER GUMMI		220x40	4			
17	3100194	LAAKERI LAGER BEARING LAGER	WB 802 6060		2			0.23
18	3010685	RUIUVI SKRUV SCREW SCHRAUBE	KKR M10X25 8.8 DIN 912 ZN		12			0
19	3010138	RUIUVI SKRUV SCREW SCHRAUBE	KKR M10X60 8.8 ZN DIN 912		4			0
20	3010192	RUIUVI SKRUV SCREW SCHRAUBE	KKR M10 X 20 8.8 ZN DIN 912		4			0
21	3030003	ALUSLEVY BRICKA WASHER UNTERLEGSCHEIBE	M10/11 ZN DIN 126		20			0
22	3050003	RASVANIPPA SMÖRJNIPPEL GREASE NIPPLE SCHMIERNIPPEL	M8X1,25 DIN 71412		1			0
100	3131151	LETKU SLANG HOSE SCHLAUCH	5601-12/HI33-12/5601-12, L=1200		2			

90022008

NOSTOPUOMI

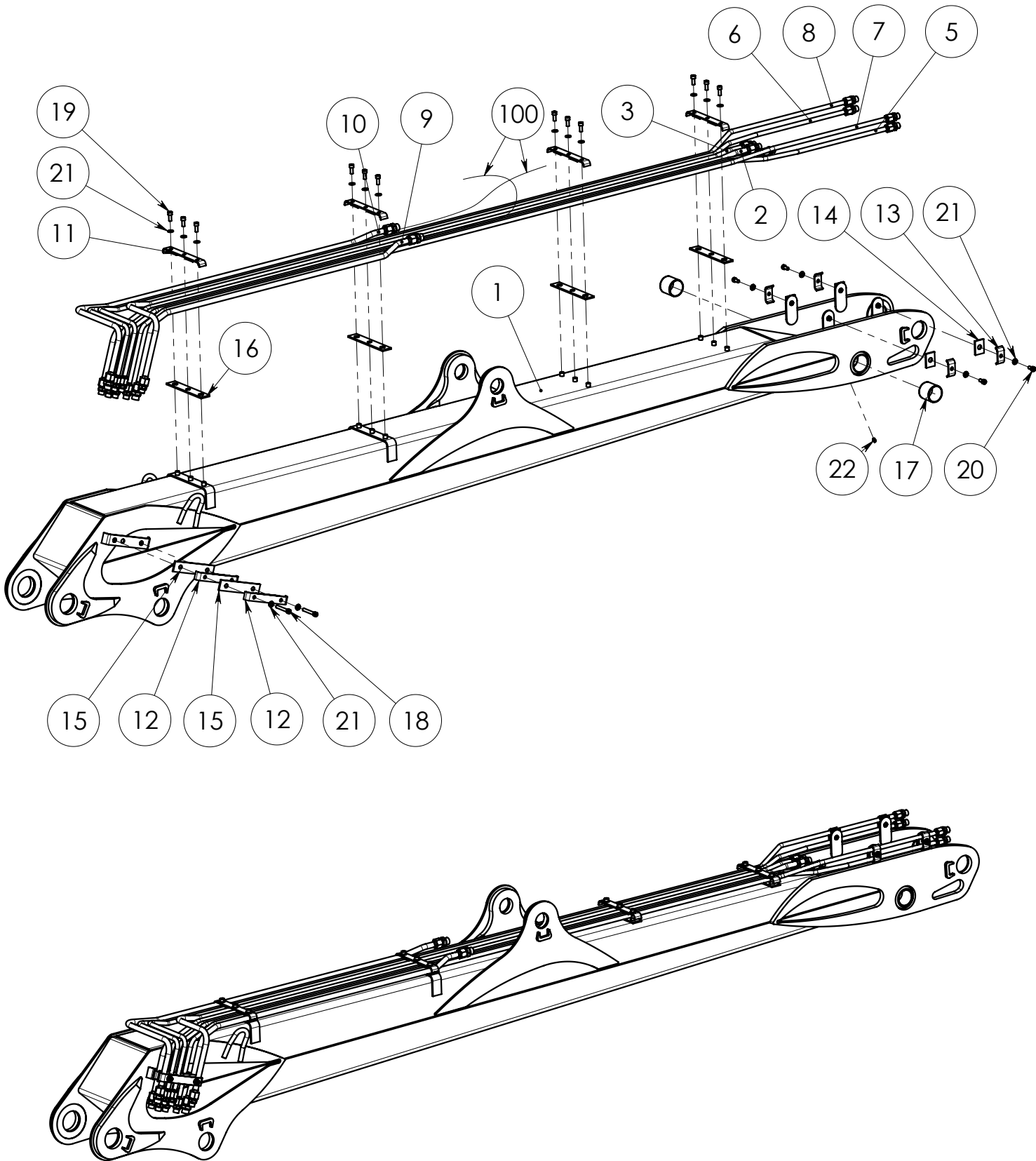



SPARE PART LIST

Item code	90022008	Revision	-
Title	NOSTOJUOMI	Date	31.07.2007
Specification	HYTTI VAR		

Pos	Item code	Title	Specification	Dimensions	Pc	Amount	Unit	Nto Weight
1	90021886	PUOMI BOM BOOM ARM	KONESTUS		1			275
2	90021993	PUTKI RÖR PIPE ROHR	1 OIKEA KOK		1			4.42
3	90022010	PUTKI RÖR PIPE ROHR	1 VASEN KOK		1			4.44
4	90021996	PUTKI RÖR PIPE ROHR	2 OIKEA KOK		1			2.94
5	90021994	PUTKI RÖR PIPE ROHR	3 OIKEA KOK		1			3.3
6	90022012	PUTKI RÖR PIPE ROHR	3 VASEN KOK		1			3.43
7	90021997	PUTKI RÖR PIPE ROHR	4 OIKEA KOK		1			3.27
8	90022014	PUTKI RÖR PIPE ROHR	4 VASEN KOK		1			3.46
9	90021992	PUTKI RÖR PIPE ROHR	5 OIKEA KOK		1			2.57
10	90022018	PUTKI RÖR PIPE ROHR	5 VASEN KOK		1			2.96
11	90021956	KIINNIKE FÄSTE FASTENER BEFESTIGUNG	HITS		4			0.31
12	90021960	KIINNIKE FÄSTE FASTENER BEFESTIGUNG	HITS		2			0.3
13	90010442	KIINNIKE FÄSTE FASTENER BEFESTIGUNG	LT4X30-72	L=72	4			0.07
14	90010443	KUMI GUMMI RUBBER GUMMI		55x40	4			0.01
15	90021961	KUMI GUMMI RUBBER GUMMI		190x40	2			
16	90013489	KUMI GUMMI RUBBER GUMMI		220x40	4			
17	3100194	LAAKERI LAGER BEARING LAGER	WB 802 6060		2			0.23
18	3010274	RUUVI SKRUV SCREW SCHRAUBE	KKR M10 X 70 8.8 ZN DIN 912		2			0
19	3010685	RUUVI SKRUV SCREW SCHRAUBE	KKR M10X25 8.8 DIN 912 ZN		12			0
20	3010192	RUUVI SKRUV SCREW SCHRAUBE	KKR M10 X 20 8.8 ZN DIN 912		4			0
21	3030003	ALUSLEVY BRICKA WASHER UNTERLEGSCHEIBE	M10/11 ZN DIN 126		18			0
22	3050003	RASVANIPPA SMÖRJNIPPEL GREASE NIPPLE SCHMIERNIPPEL	M8X1,25 DIN 71412		1			0
100	3131151	LETKU SLANG HOSE SCHLAUCH	5601-12/HI33-12/5601-12, L=1200		2			

90022298

PUOMI

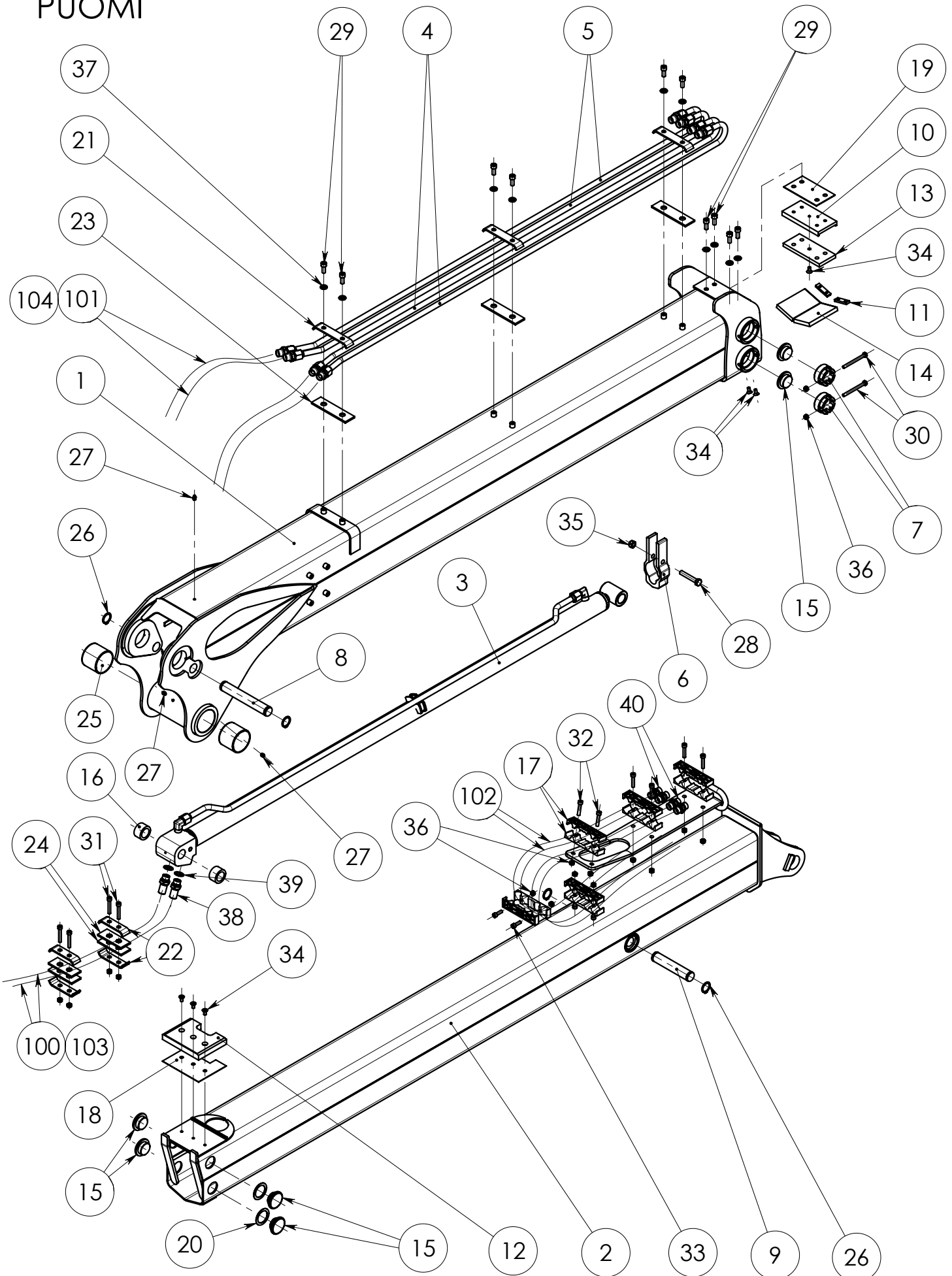

18, 19, 20 vain tarvittaessa



SPARE PART LIST

Item code	90022298	Revision	-
Title	PUOMI	Date	05.02.2008
Specification	1-JATK		

Pos	Item code	Title	Specification	Dimensions	Pc	Amount	Unit	Nto Weight
1	90022281	PUOMI BOM BOOM ARM	KONESTUS		1			107.24
2	90022290	JATKE UTSKJUT EXTENSION AUSSCHUB	HITS		1			70.87
3	28586001	SYLINTERI CYLINDER ZYLINDER	50/30X1600		1			6.56
4	90019691	PUTKI RÖR PIPE ROHR	OIKEA KOK		2			1.92
5	90019692	PUTKI RÖR PIPE ROHR	VASEN KOK		2			1.92
6	90018359	TUKI STÖD SUPPORT STÜTZE		173x72	1			0.99
7	90016090	KIINNIKE FÄSTE FASTENER BEFESTIGUNG		L=37	4			0.35
8	90021934	AKSELI AXEL AXLE ACHSE	30X196	L=156	1			1.08
9	90014885	AKSELI AXEL AXLE ACHSE	30-154	L=156	1			0.85
10	90014762	KIINNIKE FÄSTE FASTENER BEFESTIGUNG		L=182	1			1.01
11	90010345	PIDIKE FÄSTE HOLDER GESTELL		52x15	2			0.03
12	90021936	LIUKUPALA GLIDKLACK GLIDE PAD GLEITLAGER	20X120X155	155x120	1			0.31
13	90014766	LIUKUPALA GLIDKLACK GLIDE PAD GLEITLAGER	50X130	155x70	1			0.12
14	90012374	LIUKUPALA GLIDKLACK GLIDE PAD GLEITLAGER	70X 120	120x70	2			0.1
15	90011001	LIUKUPALA GLIDKLACK GLIDE PAD GLEITLAGER	D=55-19/7	L=20	8			0.03
16	90021928	HOLKKI HYLSA SLEEVE ACHSHALTER	45/31-26	L=28	2			0.02
17	3301209	KIINNIKE FÄSTE FASTENER BEFESTIGUNG	LETKUNKIINNIKE		10			0.19
18	90017085	LEVY PLÅT PLATE PLATTE	119X155	155x119	1			0.13
19	90015125	ALUSLEVY BRICKA WASHER UNTERLEGSCHEIBE	2.0 X 80 X 140	140x80	1			0.17
20	21039422	ALUSLEVY BRICKA WASHER UNTERLEGSCHEIBE	1XD=55	55x55	2			0.01
21	90012248	KIINNIKE FÄSTE FASTENER BEFESTIGUNG	4X30-152	L=152	3			0.14
22	90013168	KIINNIKE FÄSTE FASTENER BEFESTIGUNG	4X30-112	L=112	4			0.1
23	90010444	KUMI GUMMI RUBBER GUMMI	5X40-145	145x40	3			
24	90013174	KUMI GUMMI RUBBER GUMMI		100x40	4			0.02
25	3100185	LAAKERI LAGER BEARING LAGER	WB 802 7060		2			0.27
26	3060092	PIDÄTINRENGAS LÅSRING SNAPRING SPRENGRING	AS30X2 DIN 471		4			0
27	3050003	RASVANIPPA SMÖRJNIPPEL GREASE NIPPLE SCHMIERNIPPEL	M8X1,25 DIN 71412		3			0
28	3010152	RUUVI SKRUV SCREW SCHRAUBE	KR M12 X 70 8.8 ZN DIN 931		1			0
29	3010685	RUUVI SKRUV SCREW SCHRAUBE	KKR M10X25 8.8 DIN 912 ZN		10			0
30	3010328	RUUVI SKRUV SCREW SCHRAUBE	KR M8 X 90 8.8 ZN DIN 931		4			0
31	3010050	RUUVI SKRUV SCREW SCHRAUBE	KKR M8 X 50 8.8 ZN DIN 912		4			0
32	3010250	RUUVI SKRUV SCREW SCHRAUBE	KKR M8 X 40 8.8 ZN DIN 912		6			0
33	3010291	RUUVI SKRUV SCREW SCHRAUBE	KKR M8 X 25 8.8 ZN DIN 912		4			0
34	3010190	RUUVI SKRUV SCREW SCHRAUBE	KKR M8X16 10.9 DIN 7991		8			0
35	3020005	MUTTERI MUTTER NUT MUTTER	KM M12 ZN DIN 985		1			0
36	3020001	MUTTERI MUTTER NUT MUTTER	KM M8 ZN DIN 985		18			0



SPARE PART LIST

Item code	90022298	Revision	-
Title	PUOMI	Date	05.02.2008
Specification	1-JATK		

Pos	Item code	Title	Specification	Dimensions	Pc	Amount	Unit	Nto Weight
37	3030003	ALUSLEVY BRICKA WASHER UNTERLEGSCHEIBE	M10/11 ZN DIN 126		10			0
38	3090297	LIITIN KOPPLINGSKYCKE CONNECTOR KONNEKTOR	04000-08 EP		2			0.12
39	3110042	TIIVISTE TÄTINING SEAL DICHTUNG	USIT R-08 (R1/2")		2			0.01
40	3090019	LIITIN KOPPLINGSKYCKE CONNECTOR KONNEKTOR	04000-08 (R1/2")		4			0.1
100	3130737	LETKU SLANG HOSE SCHLAUCH	5701-08/H184-08/5701-08 L=900		2			0.74
101	3130456	LETKU SLANG HOSE SCHLAUCH	5701-08/H184-08/5701-08/L=1050		4			0.84
102	3130473	LETKU SLANG HOSE SCHLAUCH	5701-08/H184-08/5701-08/L=1900		4			
103	3130979	SUOJA SKYDD COVER SCHUTZ	D=32 MUSTA		2		m	0.18
104	3130734	SUOJA SKYDD COVER SCHUTZ	D=50		2		m	0.33

VARAOSAT \ RESERVDLAR \ SPARE PARTS \ ERSATZTEIL

90021963

PUOMI

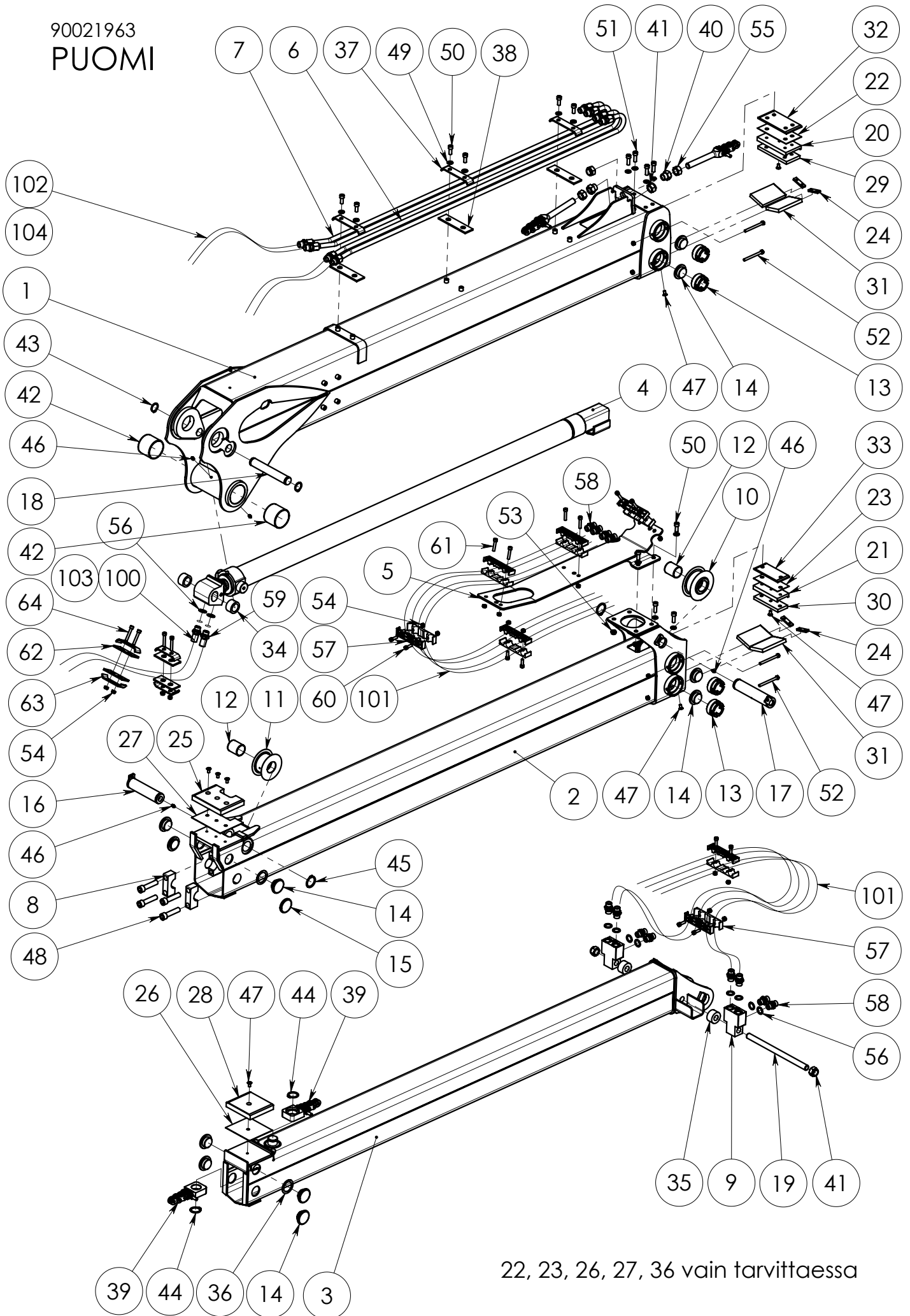

22, 23, 26, 27, 36 vain tarvittaessa



OSALUETTELO

Nimikenumero	90021963	Revisio	-
Nimitys	PUOMI	Päiväys	29.06.2007
Specifikaatio	SIIRTOPUOMI 2-JATK	Liitty	

Pos	Nimike n:o	Nimitys + Specifikaatio	Mitat	Kpl	Määrä	Yks	Nto paino	Huom
1	90021910	PUOMI KONEISTUS		1			107.96	
2	90021938	JATKE KONEISTUS		1			71.03	
3	90021940	JATKE HITSAUS		1			51.59	
4	28581001	SYLINTERI 70/40-1600		1			25.94	
5	90021904	OHJAIN HITS		1			6.00	
6	90021906	PUTKI OIKEA KOK		2			1.75	
7	90021908	PUTKI VASEN KOK		2			1.75	
8	90021909	KANSI	90x40	2			0.40	
9	90021920	LIITIN	L=77	2			0.55	
10	90021697	PYÖRÄ R1", 3X4	L=53	1			1.96	
11	90010136	PYÖRÄ D=75	L=53	1			1.34	
12	3100188	LAAKERI WB 802 4050		2			0.10	
13	90016090	KIINNIKE	L=37	8			0.35	
14	90011001	LIUKUPALA D=55-19/7	L=20	14			0.03	
15	90020689	LIUKUPALA 40X55-7X5	L=20	2			0.03	
16	90021930	AKSELI 40-156 HITS		1			1.52	
17	90021933	AKSELI 40-184 HITS		1			1.79	
18	90021934	AKSELI 30X196	L=216	1			1.08	
19	90021935	RUUVI M20-320	L=323	1			0.79	
20	90014762	KIINNIKE	L=182	1			1.01	
21	90014763	KIINNIKE	L=132	1			0.65	
22	90015124	LEVY 80 X 155	L=55x80	1			0.09	
23	90015142	LEVY 60 X 130	130x60	1			0.06	
24	90010345	PIDIKE	52x15	4			0.03	
25	90021936	LIUKUPALA 20X120X155	155x120	1			0.31	
26	90017020	ALUSLEVY 1X119X130	130x119	1			0.12	
27	90017085	LEVY 119X155	155x119	1			0.13	
28	90021937	LIUKUPALA 20X120X130	130x120	1			0.29	
29	90014766	LIUKUPALA 50X130	155x70	1			0.12	
30	90014770	LIUKUPALA 50X130	130x50	1			0.07	
31	90012374	LIUKUPALA 70X 120	120x70	4			0.10	
32	90021950	LEVY	155x80	1			0.07	
33	90021952	LEVY	130x60	1			0.04	
34	90021928	HOLKKI 45/31-26	L=28	2			0.02	
35	90021953	HOLKKI 40/21-26	L=28	2			0.03	
36	21039422	ALUSLEVY 1XD=55	55x55	2			0.01	



OSALUETTELO

Nimikenumero	90021963	Revisio	-
Nimitys	PUOMI	Päiväys	29.06.2007
Specifikaatio	SIIRTOPUOMI 2-JATK	Liitty	

Pos	Nimike n:o	Nimitys + Specifikaatio	Mitat	Kpl	Määrä	Yks	Nto paino	Huom
37	90012248	KIINNIKE 4X30-152	L=152	3			0.14	
38	90010444	KUMI 5X40-145	145x40	3				
39	90021892	KETJU 3X4 (81 LENKKIÄ) KOK		4			1.81	
40	90017520	MUTTERI M20-30	L=32	2			0.09	
41	3020009	MUTTERI KM M20 ZN DIN 985		4			0.00	
42	3100185	LAAKERI WB 802 7060		2			0.27	
43	3060092	PIDÄTINRENGAS AS30X2 DIN 471		2			0.00	
44	3060091	PIDÄTINRENGAS AS 35X2.5 DIN 471		2			0.00	
45	3060100	PIDÄTINRENGAS AS 40X2.5 DIN 471		2			0.00	
46	3050022	RASVANIPPA M8X1		5			0.00	
47	3010190	RUUVI KKR M8X16 10.9 DIN 7991		14			0.00	
48	3010277	RUUVI KKR M16 X 70 12.9 ZN DIN 912		4			0.00	
49	3030003	ALUSLEVY M10/11 ZN DIN 126		16			0.00	
50	3010685	RUUVI KKR M10X25 8.8 DIN 912 ZN		10			0.00	
51	3010248	RUUVI KKR M10 X 30 8.8 ZN DIN 912		6			0.00	
52	3010328	RUUVI KR M8 X 90 8.8 ZN DIN 931		8			0.00	
53	3020004	MUTTERI KM M10 ZN DIN 985		4			0.00	
54	3020001	MUTTERI KM M8 ZN DIN 985		26			0.00	
55	3020032	MUTTERI KM M20 ZN DIN 934/8		2			0.00	
56	3110042	TIVISTE USIT R-08 (R1/2')		10			0.01	
57	3301209	KIINNIKE LETKUNKIINNIKE		14				
58	3090019	LIITIN 04000-08 (R1/2')		12			0.10	
59	3090297	LIITIN 04000-08 EP		2			0.12	
60	3010291	RUUVI KKR M8 X 25 8.8 ZN DIN 912		8			0.00	
61	3010250	RUUVI KKR M8 X 40 8.8 ZN DIN 912		6			0.00	
62	90013174	KUMI		4			0.02	
63	90013168	KIINNIKE 4X30-112	L=112	4			0.10	
64	3010050	RUUVI KKR M8 X 50 8.8 ZN DIN 912		4			0.00	
100	3130737	LETKU 5701-08/HI84-08/5701-08 L=900		2			0.74	
101	3132566	LETKU 5701-08/HI84-08/5701-08/L=2050		8				
102	3130456	LETKU 5701-08/HI84-08/5701-08/L=1050		4			0.84	
103	3130979	SUOJA D=32 MUUSTA		2	.6	m	0.18	
104	3130734	SUOJA D=50		2	.9	m	0.33	

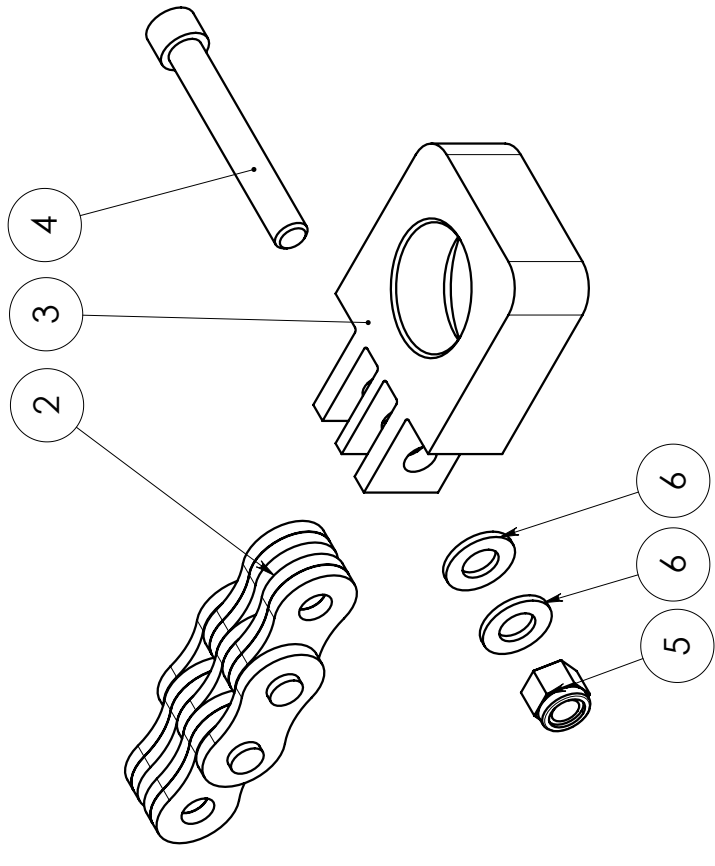
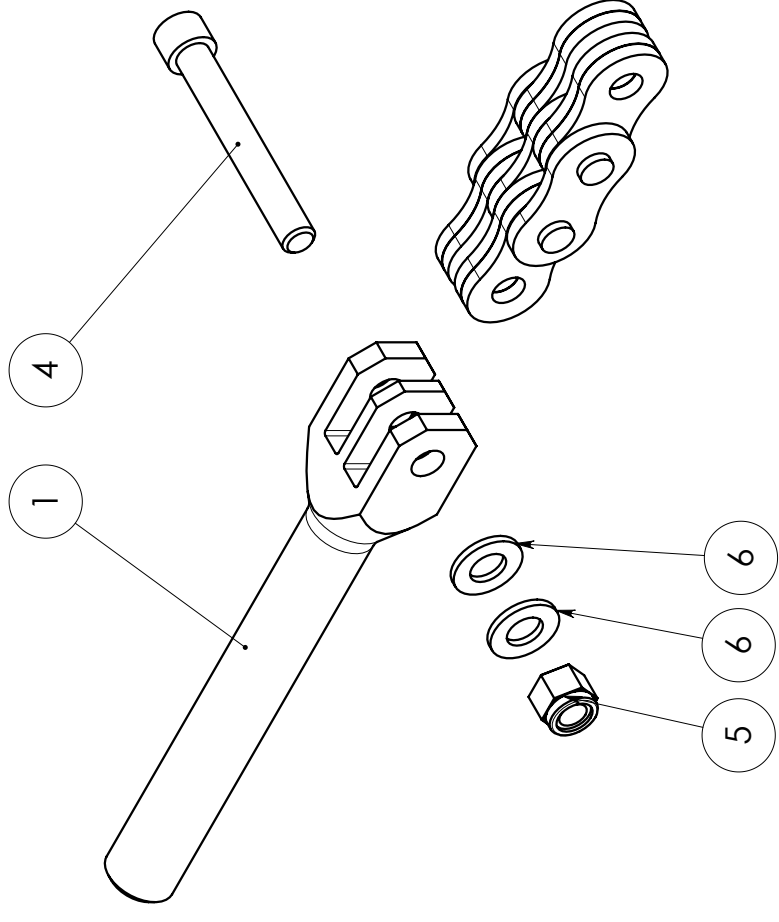

90021892

KETJU

VARAOSAT \ RESERVDALAR \ SPARE PARTS \ ERSATZTEIL



SPARE PART LIST

Item code	90021892	Revision	-
Title	KETJU	Date	20.12.2007
Specification	3X4 (81 LENKKIÄ) KOK		

Pos	Item code	Title	Specification	Dimensions	Pc	Amount	Unit	Nto Weight
1	90021136	KIRISTIN SPÄNNARE TENSIONER VERSCHLUSS	R 1"	185x36	1			0.52
2	3190118	KETJU KEDJA CHAIN KETTE	R 1" (81 LENKKIÄ)		1			0.33
3	90021137	LIITIN KOPPLINGSSTYCKE CONNECTOR KONNEKTOR	R 1"	90x60	1			0.53
4	3010857	RUUVI.SKRUV. SCREW SCHRAUBE	UNC 3/8"x2 3/4" 12.9		2			0.05
5	3020181	MUTTERI MUTTER NUT MUTTER	UNC 3/8" DIN985		2			
6	3030065	ALUSLEVY BRICKA WASHER UNTERLEGSCHIBE	M10 ZN DIN 125		4			0

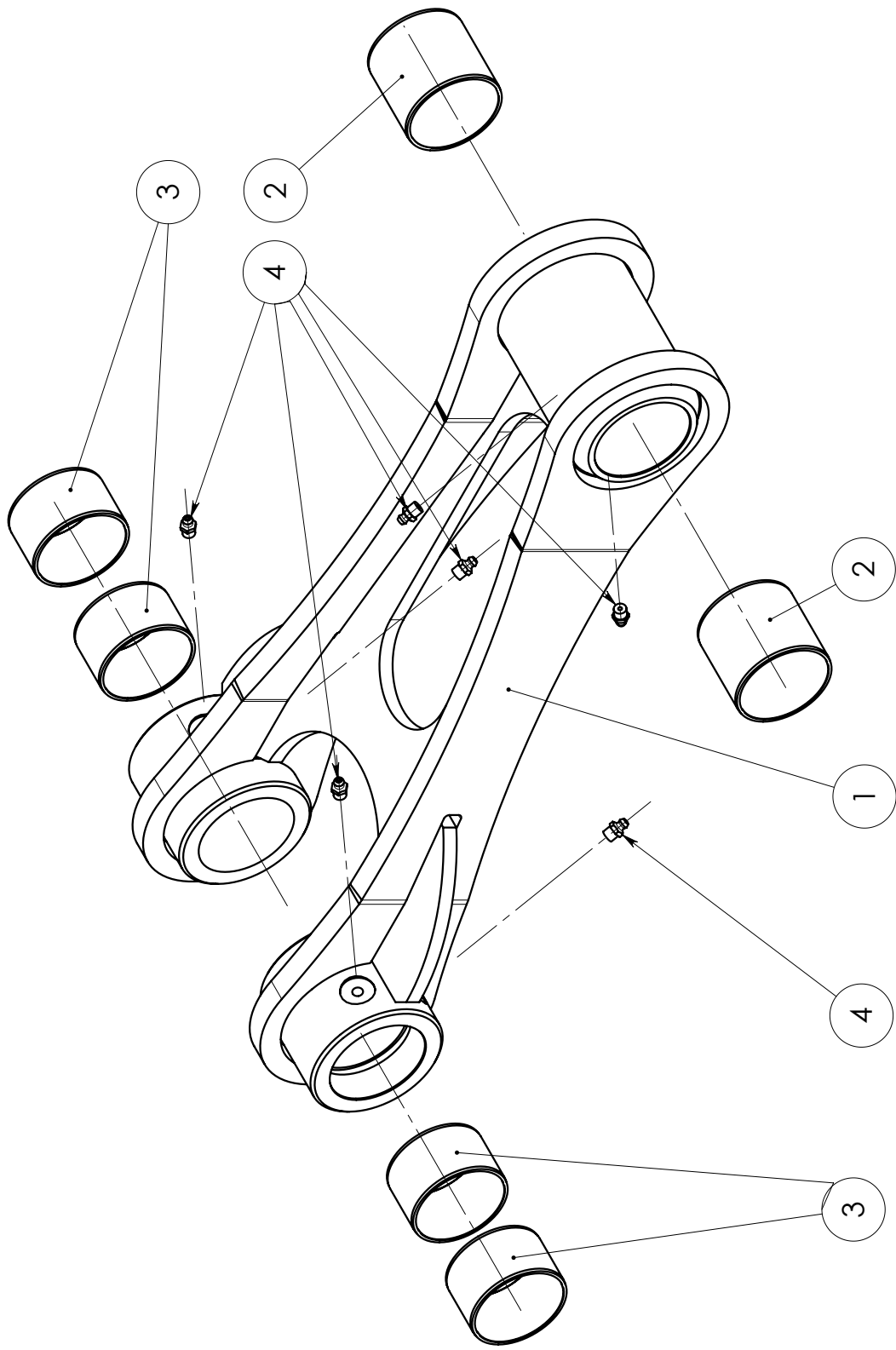

90017910 TANKO

VARAOSAT \ RESERVDLAR \ SPARE PARTS \ ERSATZTEIL



SPARE PART LIST

Item code	90017910	Revision	-
Title	TANKO	Date	27.06.2007
Specification	VAR		

Pos	Item code	Title	Specification	Dimensions	Pc	Amount	Unit	Nto Weight
1	90017902	TANKO LÄNK LINK GELENK	KONESTUS		1			18.12
2	3100194	LAAKERI LAGER BEARING LAGER	WB 802 6060		2			0.23
3	3100186	LAAKERI LAGER BEARING LAGER	WB 802 6040		4			0.15
4	3050003	RASVANIPPA SMÖRJNIPPEL GREASE NIPPLE SCHMIERNIPPEL	M8X1,25 DIN 71412		6			0

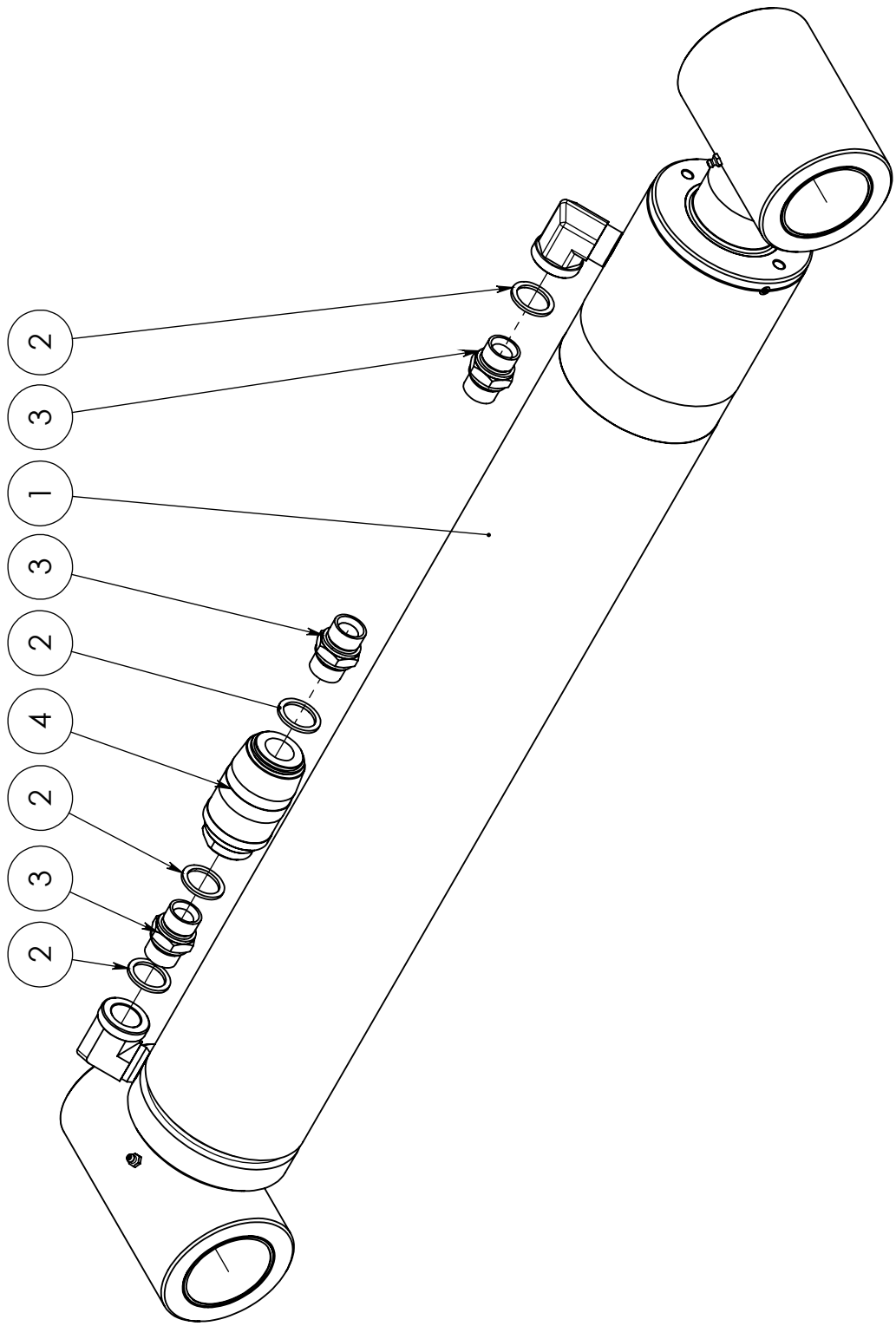

90022184 SYLINTERI

VARAOSAT \ RESERVDLAR \ SPARE PARTS \ ERSATZTEIL



SPARE PART LIST

Item code	90022184	Revision	-
Title	SYLINTERI	Date	07.11.2007
Specification	120/70 X 800		

Pos	Item code	Title	Specification	Dimensions	Pc	Amount	Unit	Ntto Weight
1	28810001	SYLINTERI CYLINDER ZYLINDER	120/70 X 800		1			29.35
2	3110130	TIIVISTE TÄTNIING SEAL DICHTUNG	USIT R-12 (R3/4")		4			0.01
3	3090185	LIITIN KOPPLINGSSTYCKE CONNECTOR KONNEKTOR	04000-12		3			0.14
4	3120235	VENTTIILI VENTIL VALVE VENTIL			1			1.24

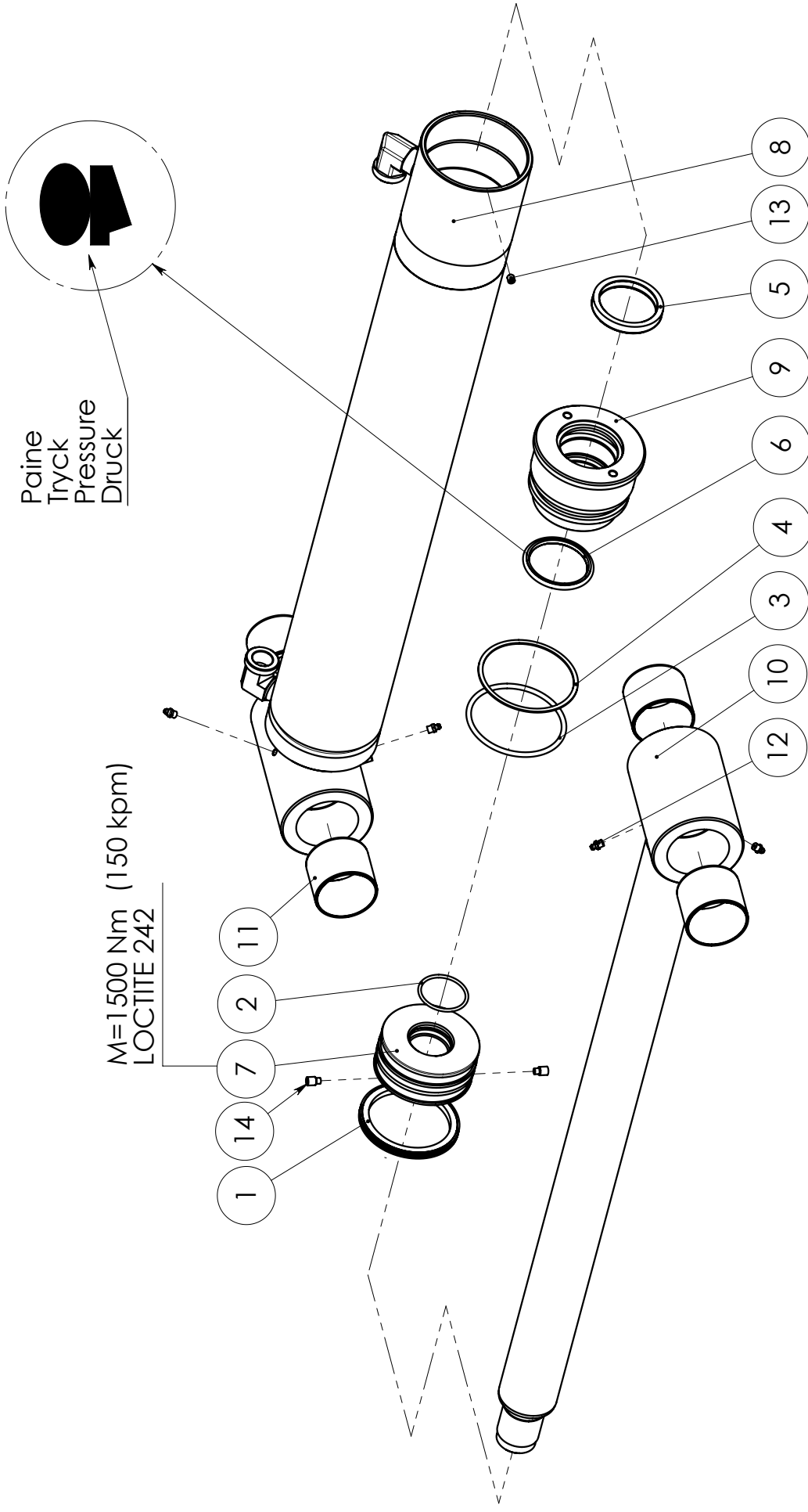

NOSTO-
SYLINTERI

28810001



SPARE PART LIST

Item code	28810001	Revision	-
Title	SYLINTERI	Date	23.05.2007
Specification	120/70 X 800		

Pos	Item code	Title	Specification	Dimensions	Pc	Amount	Unit	Nto Weight
1	3110813	TIIVISTE TÄTNIING SEAL DICHTUNG	OK 120/99X8		1			0.22
2	3110203	TIIVISTE TÄTNIING SEAL DICHTUNG	O 53.57 X 3.53 90 SH		1			0.01
3	3110277	TIIVISTE TÄTNIING SEAL DICHTUNG	O 109.2 X 5.7 90 SHORE		1			0.07
4	3110200	TIIVISTE TÄTNIING SEAL DICHTUNG	TR 120/110X1.7 PU		1			0
5	3110195	TIIVISTE TÄTNIING SEAL DICHTUNG	HALLITE 621 70/85X11.4		1			0.12
6	3110197	TIIVISTE TÄTNIING SEAL DICHTUNG	PO-55-150-0700		1			0.07
7	28688201	MÄNTÄ KOLV PISTON KOLBEN	120	L=73	1			3.6
8	28810101	SYLINTERIPUTKI CYLINDERROHR	120/70 X 800		1			11.66
9	28688202	OHJAIN STYRNING GUIDANCE STEUERUNG	120/70	L=91	1			4.82
10	28810204	MÄNNÄNVARSI KOLVSTÄNG PISTON ROD KOLBENSTANGE	120/70 X 800		1			7.14
11	3100185	LAAKERI LAGER BEARING LAGER	WB 802 7060		4			0.27
12	3050003	RASVANIPPA SMÖRJNIPPEL GREASE NIPPLE SCHMIERNIPPEL	M8X1,25 DIN 71412		4			0
13	3010175	RUUVI SKRUV SCREW SCHRAUBE	KK M8 X 10 ZN DIN 914		1			0
14	3010240	RUUVI SKRUV SCREW SCHRAUBE	KK-PID.RUUVI M10X16 8.8 ZN DIN 915		2			0
1-9	3110815	TIIVISTE TÄTNIING SEAL DICHTUNG	SARJA 120/70		1		sj	

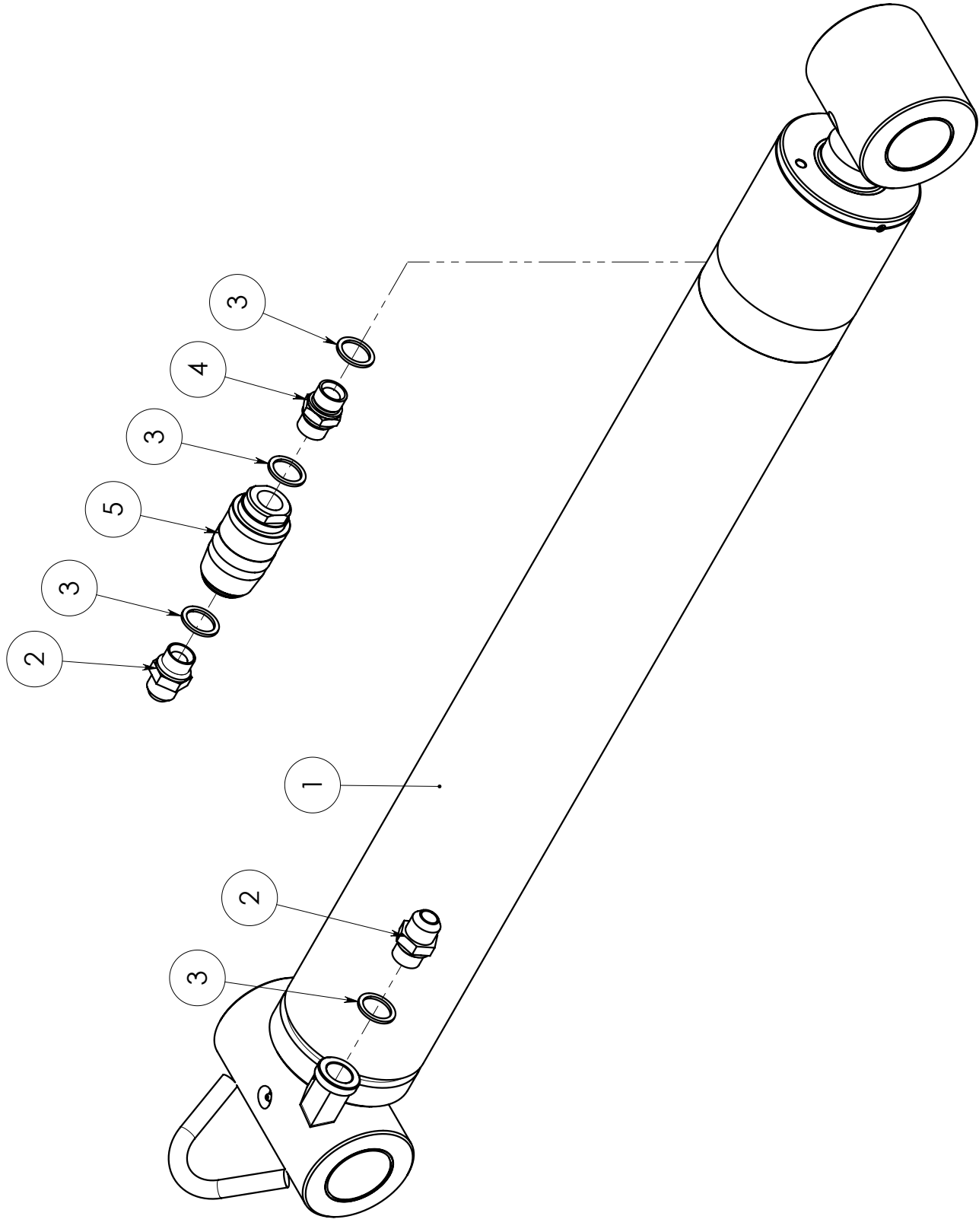

90022183 SYLINTERI

VARAOSAT \ RESERVELAR \ SPARE PARTS \ ERSATZTEIL



SPARE PART LIST

Item code	90022183	Revision	-
Title	SYLINTERI	Date	19.12.2007
Specification	120X60X908		

Pos	Item code	Title	Specification	Dimensions	Pc	Amount	Unit	Nto Weight
1	28811001	SYLINTERI CYLINDER ZYLINDER	120/60 X 908		1			29.94
2	3090918	LIITIN KOPPLINGSKYCKE CONNECTOR KONNEKTOR	26-04001-12-12 JIC (R3/4"- 1 1/16" JIC)		2			0.16
3	3110130	TIIVISTE TÄTNING SEAL DICHTUNG	USIT R-12 (R3/4")		4			0.01
4	3090185	LIITIN KOPPLINGSKYCKE CONNECTOR KONNEKTOR	04000-12		1			0.14
5	3120235	VENTTIILI VENTIL VALVE VENTIL			1			1.24

M=1500 Nm (150 kpm)
LOCTITE 242

LOCTITE 242

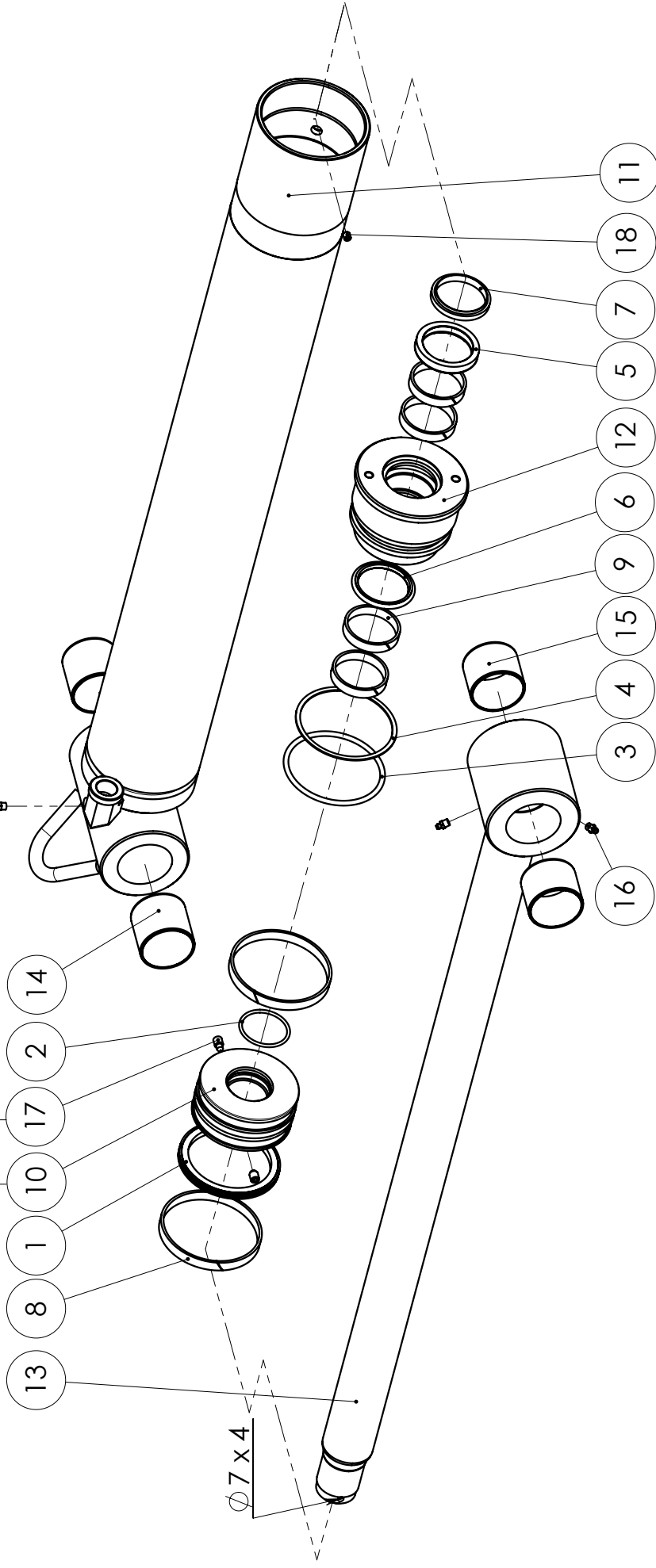

28811001 SYLINTERI

VARAOSAT \ RESERVDELAR \ SPARE PARTS \ ERSATZTEIL



SPARE PART LIST

Item code	28811001	Revision	-
Title	SYLINTERI	Date	07.06.2007
Specification	120/60 X 908		

Pos	Item code	Title	Specification	Dimensions	Pc	Amount	Unit	Nto Weight
1	3110813	TIIVISTE TÄTNIING SEAL DICHTUNG	OK 120/99X8		1			0.22
2	3110203	TIIVISTE TÄTNIING SEAL DICHTUNG	O 53.57 X 3.53 90 SH		1			0.01
3	3110277	TIIVISTE TÄTNIING SEAL DICHTUNG	O 109.2 X 5.7 90 SHORE		1			0.07
4	3110200	TIIVISTE TÄTNIING SEAL DICHTUNG	TR 120/110X1.7 PU		1			0
5	3110315	TIIVISTE TÄTNIING SEAL DICHTUNG	HALLITE 621 60/75X11.4		1			0.11
6	3110884	TIIVISTE TÄTNIING SEAL DICHTUNG	OMS-MR 60/75.1X6		1			0.06
7	3110188	TIIVISTE TÄTNIING SEAL DICHTUNG	GA 60/70 X 7/10		1			0.06
8	3110814	OHJAIN STYRNING GUIDANCE STEUERUNG	E/PWR 120/114X13		2			0.11
9	3110759	OHJAIN STYRNING GUIDANCE STEUERUNG	I/PWR 60/66 X13		4			0.06
10	28688201	MÄNTÄ KOLV PISTON . KOLBEN	120	L=73	1			3.6
11	28811101	SYLINTERIPUTKI CYLINDERBÄRREL ZYLINDERROHR	120/60 X 908		1			12.3
12	28689202	OHJAIN STYRNING GUIDANCE STEUERUNG	120/60	L=91	1			5.66
13	28811204	MÄNNÄNVARSI KOLVSTÄNG PISTON ROD KOLBENSTANGE	120/60 X 908		1			6.55
14	3100194	LAAKERI LAGER BEARING LAGER	WB 802 6060		2			0.23
15	3100130	LAAKERI LAGER BEARING LAGER	WB 802 6050		2			0.19
16	3050003	RASVANIPPA SMÖRJNIPPEL GREASE NIPPLE SCHMIERNIPPEL	M8X1,25 DIN 71412		4			0
17	3010240	RUIUVI SKRUV SCREW SCHRAUBE	KK-PID.RUIUVI M10X16 8.8 ZN DIN 915		2			0
18	3010175	RUIUVI SKRUV SCREW SCHRAUBE	KK M8 X 10 ZN DIN 914		1			0
1-9	3110816	TIIVISTE TÄTNIING SEAL DICHTUNG	SARJA 120/60		1		sj	

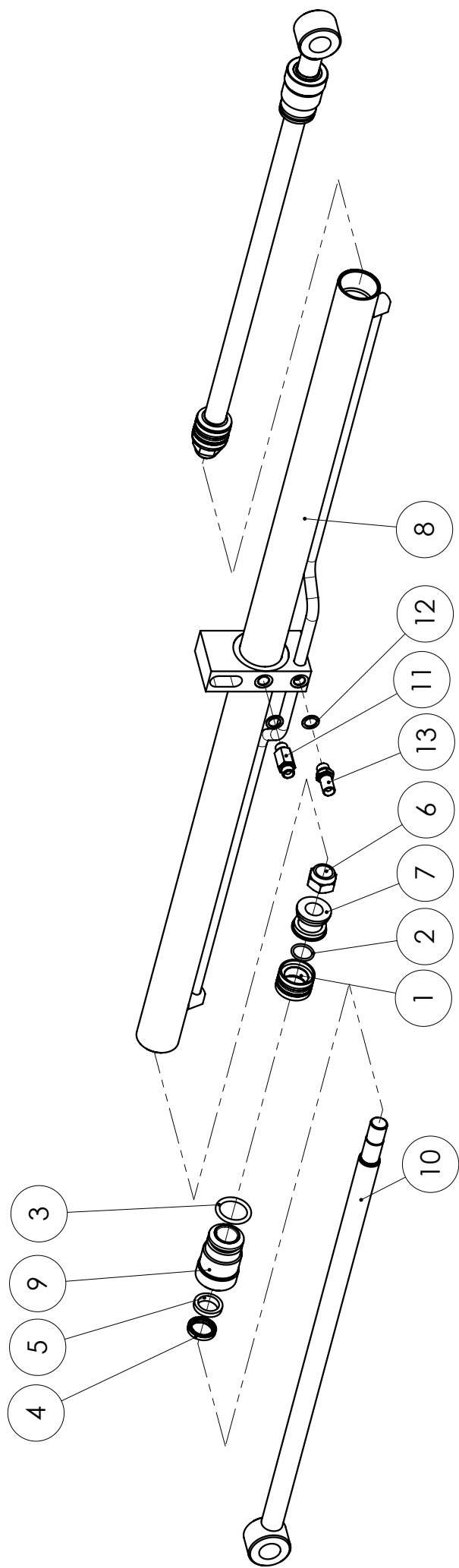

28812001

SYLINTERI

50/30 - 2x600

VARAOSAT \ RESERVDELAR \ SPARE PARTS \ ERSATZTEIL



SPARE PART LIST

Item code	28812001	Revision	-
Title	SYLINDERI	Date	06.06.2007
Specification	50/30 X 2 X 600		

Pos	Item code	Title	Specification	Dimensions	Pc	Amount	Unit	Nto Weight
1	3110013	TIIVISTE TÄTNIING SEAL DICHTUNG	DAS 50/34 X 18		2			0.18
2	3110003	TIIVISTE TÄTNIING SEAL DICHTUNG	O 26.2 X 3 70 SH		2			0.01
3	3110288	TIIVISTE TÄTNIING SEAL DICHTUNG	O 39.2 X 5.7 90 SH		2			0.03
4	3110030	TIIVISTE TÄTNIING SEAL DICHTUNG	NI300 30/40X7		2			0.02
5	3110313	TIIVISTE TÄTNIING SEAL DICHTUNG	GA 30/40 X 7/10		2			0.03
6	3020026	MUTTERI MUTTER NUT MUTTER	KM M24 ZN DIN 985		2			0
7	28337201	MÄNTÄ KOLV PISTON KOLBEN	D=50 DBM		2			0.26
8	28812101	SYLINDERIPUTKI CYLINDERÖR CYLINDER BARREL ZYLINDERROHR			1			3.76
9	28337202	OHJAIN STYRNING GUIDANCE STEUERUNG	50/30		2			0.9
10	28812204	MÄNNÄNVARSI KOLVSTÄNG PISTON ROD KOLBENSTANGE	50/30X2X600		2			0.65
11	28357106	KURISTIN STRYP RESTRICTION DROSSEL	R3/8"	L=57	1			0.12
12	3110040	TIIVISTE TÄTNIING SEAL DICHTUNG	USIT R-06 (R 3/8")		2			0
13	3090296	LIITIN KOPPLINGSSTYCKE CONNECTOR KONNEKTOR	04000-06 EP		1			0.07
1-5	3110324	TIIVISTE TÄTNIING SEAL DICHTUNG	SARJA 50/30		1		sj	

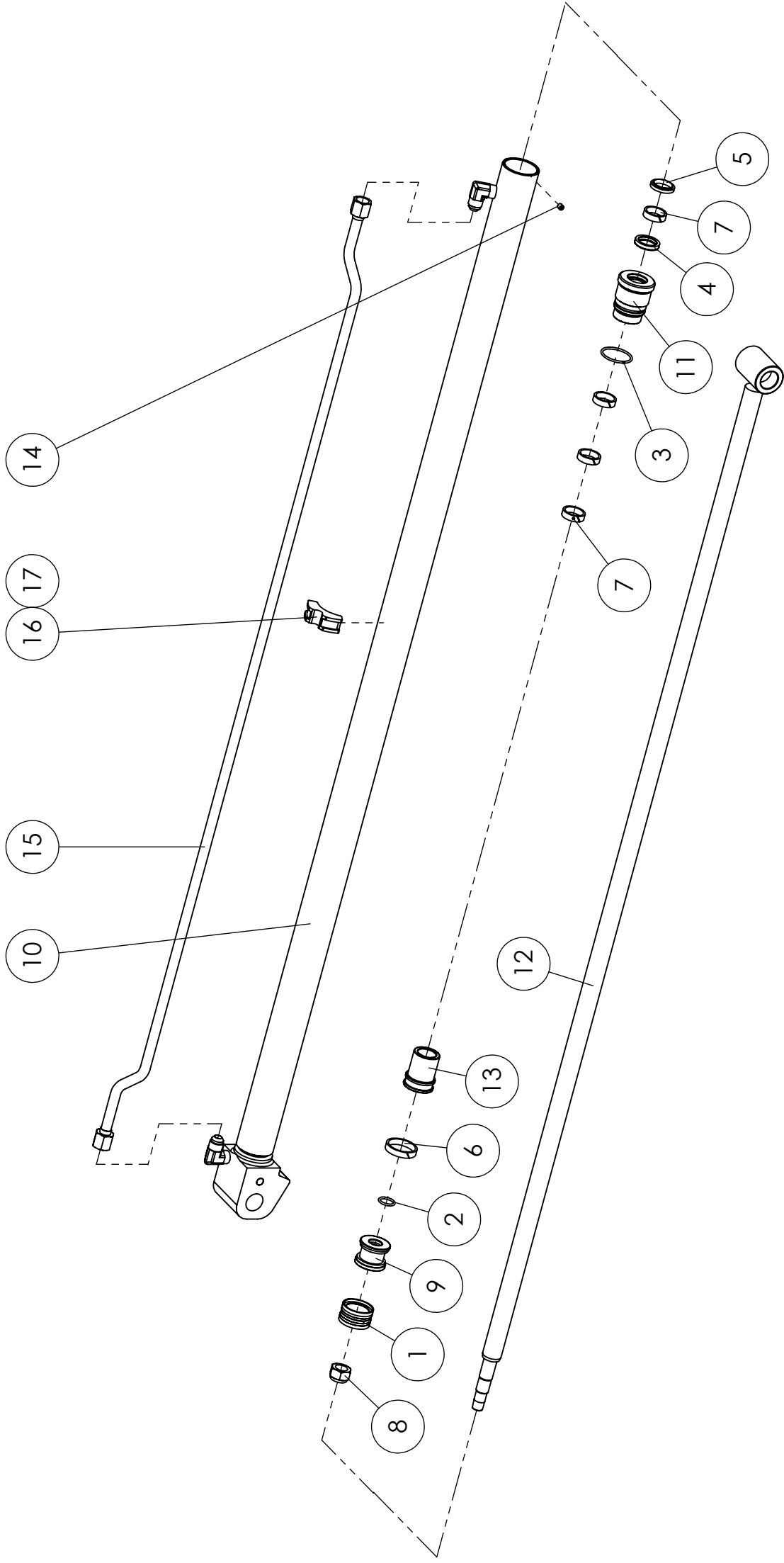

28586001 SYLINTERI

VARAOSAT \ RESERVDELAR \ SPARE PARTS \ ERSATZTEIL



SPARE PART LIST

Item code	28586001	Revision	-
Title	SYLINTERI	Date	30.10.2007
Specification	50/30X1600		

Pos	Item code	Title	Specification	Dimensions	Pc	Amount	Unit	Nto Weight
1	3110231	TIIVISTE TÄTNIING SEAL DICHTUNG	TPS 50/38 X 20		1			0.14
2	3110261	TIIVISTE TÄTNIING SEAL DICHTUNG	O 21.2 X 3 90 SH		1			0
3	3110669	TIIVISTE TÄTNIING SEAL DICHTUNG	O 45 X 3 90SH		1			0.01
4	3110030	TIIVISTE TÄTNIING SEAL DICHTUNG	NI300 30/40X7		1			0.02
5	3110027	TIIVISTE TÄTNIING SEAL DICHTUNG	PW 30		1			0.02
6	3110677	OHJAIN STYRNING GUIDANCE STEUERUNG	E/PWR 50/44X10		1			0.03
7	3110741	OHJAIN STYRNING GUIDANCE STEUERUNG	I/PWR 30/36X10		4			0.02
8	3020009	MUTTERI MUTTER NUT MUTTER	KM M20 ZN DIN 985		1			0
9	28395201	MÄNTÄ KOLV PISTON KOLBEN	50 (PDO)	L=30	1			0.31
10	28586101	SYLINTERIPUTKI CYLINDERRÖR ZYLINDERROHR	50/30-1600		1			3.84
11	28586202	OHJAIN STYRNING GUIDANCE STEUERUNG	50/30	L=72	1			0.61
12	28586204	MÄNNÄNVARSI KOLVSTÄNG PISTON ROD KOLBENSTANGE	50/30X1600		1			0.68
13	28586105	HOLKKI HYLSA SLEEVE ACHSHALTER	ISKURAJOTTINHOLKKI	L=62	1			0.37
14	3010175	RUUVI SKRUV SCREW SCHRAUBE	KK M8 X 10 ZN DIN 914		1			0
15	28586401	PUTKI RÖR PIPE ROHR			1			0.44
16	3090928	KIINNIKE FÄSTE FASTENER BEFESTIGUNG	30-ZR-518		1			
17	3090929	LIITIN KOPPLINGSSTYCKE CONNECTOR KONNEKTOR	ABA-085		1			
1-7	3110756	TIIVISTE TÄTNIING SEAL DICHTUNG	SARJA 50/30		1		sj	

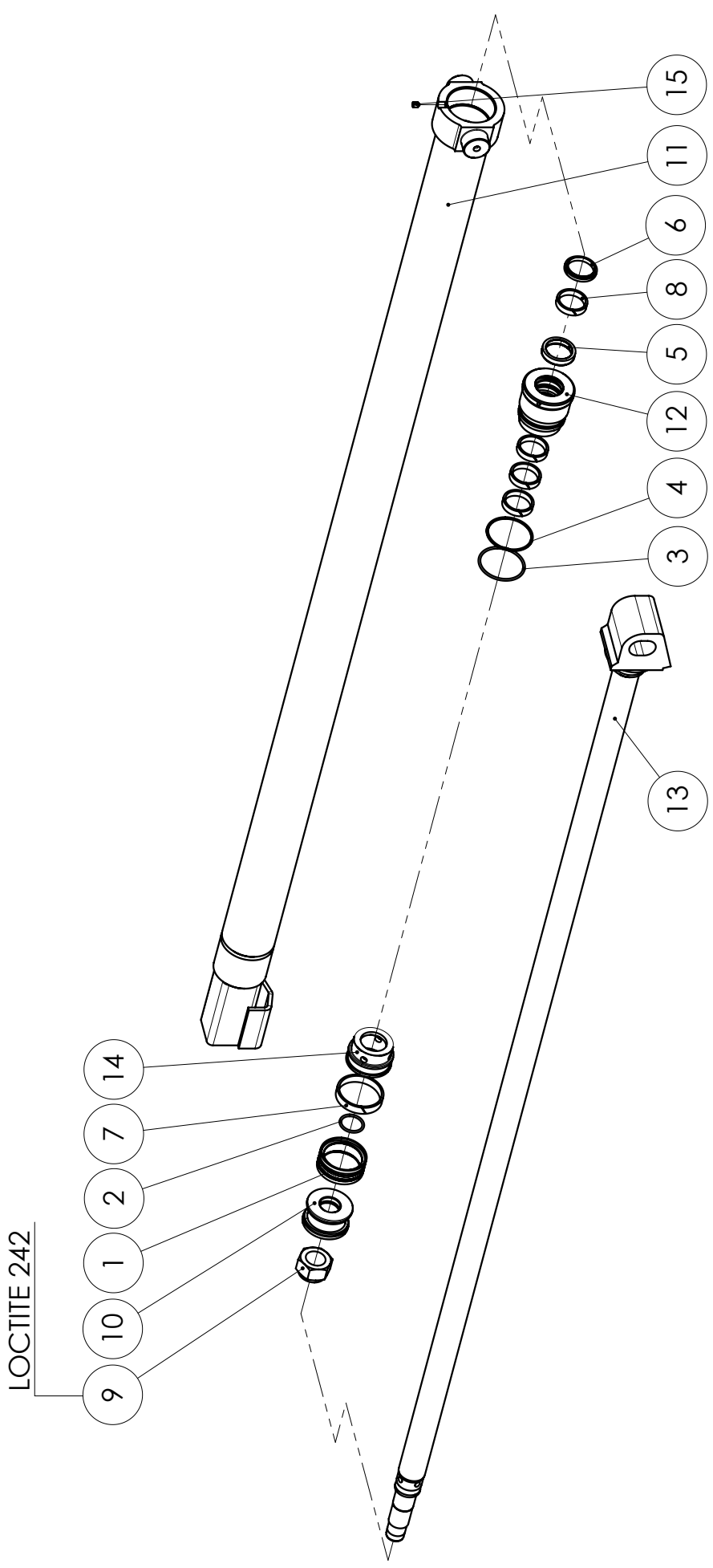

28581001 SYLINTERI

VARAOSAT \ RESERVDELAR \ SPARE PARTS \ ERSATZTEIL



SPARE PART LIST

Item code	28581001	Revision	-
Title	SYLINTERI	Date	15.06.2007
Specification	70/40-1600		

Pos	Item code	Title	Specification	Dimensions	Pc	Amount	Unit	Nto Weight
1	3110317	TIIVISTE TÄTNIING SEAL DICHTUNG	PDO 70/58 X 20		1			0.21
2	3110248	TIIVISTE TÄTNIING SEAL DICHTUNG	O 31.5 X 3 90 SH		1			0.01
3	3110009	TIIVISTE TÄTNIING SEAL DICHTUNG	O 64.5 X 3 90 SH		1			0.01
4	3110557	TIIVISTE TÄTNIING SEAL DICHTUNG	TR 70/65X1.3 PU		1			0
5	3110010	TIIVISTE TÄTNIING SEAL DICHTUNG	NI300 40/50X10		1			0.05
6	3110011	TIIVISTE TÄTNIING SEAL DICHTUNG	PW 40		1			0.03
7	3110697	OHJAIN STYRNING GUIDANCE STEUERUNG	E/PWR 70/64X13		1			0.06
8	3110735	OHJAIN STYRNING GUIDANCE STEUERUNG	I/PWR 40/46X10		4			0.03
9	3020145	MUTTERI MUTTER NUT MUTTER	KM 30X2 ZN DIN 980 V		1			0
10	28349201	MÄNTÄ KOLV PISTON - KOLBEN	D=70 (PDO-TIIV.)	L=30	1			0.64
11	28581101	SYLINTERIPUTKI CYLINDERERRÖR CYLINDER BARREL ZYLINDERROHR	70/40 X 1600		1			5.18
12	28581202	OHJAIN STYRNING GUIDANCE STEUERUNG	70/40	L=72	1			1.39
13	28581204	MÄNNÄNVARSI KOLVSTÄNG PISTON ROD KOLBENSTANGE	D=40		1			17.72
14	28581105	HOLKKI HYLSA SLEEVE ACHSHALTER	ISKURAJOTTIN	L=44	1			0.52
15	3010175	RUUVI SKRUVI SCREW SCHRAUBE	KK M8 X 10 ZN DIN 914		1			0
1-8	3110736	TIIVISTE TÄTNIING SEAL DICHTUNG	SARJA 70/40		1		sj	

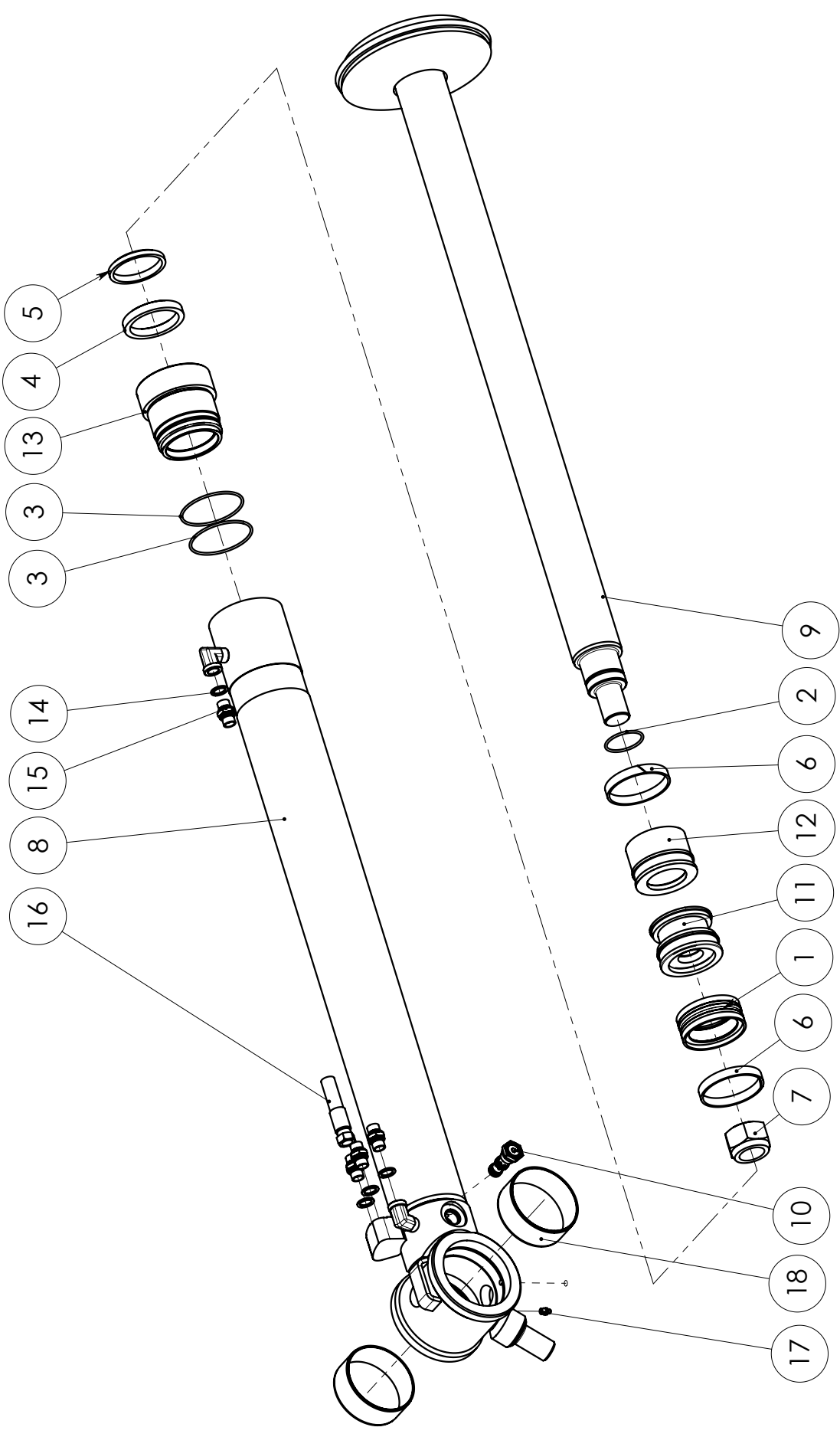

28554001 SYLINTERI



OSALUETTELO

Nimikenumero	28554001	Revisio	-
Nimitys	SYLINTERI	Päiväys	28.03.2007
Specifikaatio	TUKIJALKA KOK	Liitty	KESLA NOSTURIT

Pos	Nimike n:o	Nimitys + Specifikaatio	Mitat	Kpl	Määrä	Yks	Nto paino	Huom
1	3110025	TIIVISTE DAS 90/70 X 22		1			0.50	
2	3110278	TIIVISTE O 49.5 X 3.0 90SH		1			0.01	
3	3110017	TIIVISTE O 84.5 X 3 90 SH		2			0.02	
4	3110184	TIIVISTE B 70/85X12		1			0.18	
5	3110196	TIIVISTE GA 70/80 X 7/10		1			0.07	
6	3110397	OHJAIN E/PWR 90/84X13		2			0.08	
7	3020043	MUTTERI KM M36 X 3 ZN DIN 985		1			0.00	
8	90021719	SYLINTERIPUTKI 90_70 X 600		1			13.11	
9	28554204	MÄNNÄNVARSI 90/70-750		1			5.04	
10	3120843	VENTTIILI RPC-06/5		1			0.13	
11	28554201	MÄNTÄ D=90 DBM		1			1.34	
12	28554105	HOLKKI ISKURAJOITINHOLKKI		1			0.96	
13	28358202	OHJAIN 90/70		1			2.46	
14	3110040	TIIVISTE USIT R-06 (R 3/8")		4			0.00	
15	3090040	LIITIN 04000-06		4			0.06	
16	3131328	LETKU 5701-06/HI98-06/5701-06/L=850		1				
17	3050003	RASVANIPPA M8X1,25 DIN 71412		3			0.00	
18	3100288	LAAKERI WB802 10040		2			0.25	
1-6	3110430	TIIVISTE SARJA 90/70		1	1	srj		

90012142

RIIPUKE

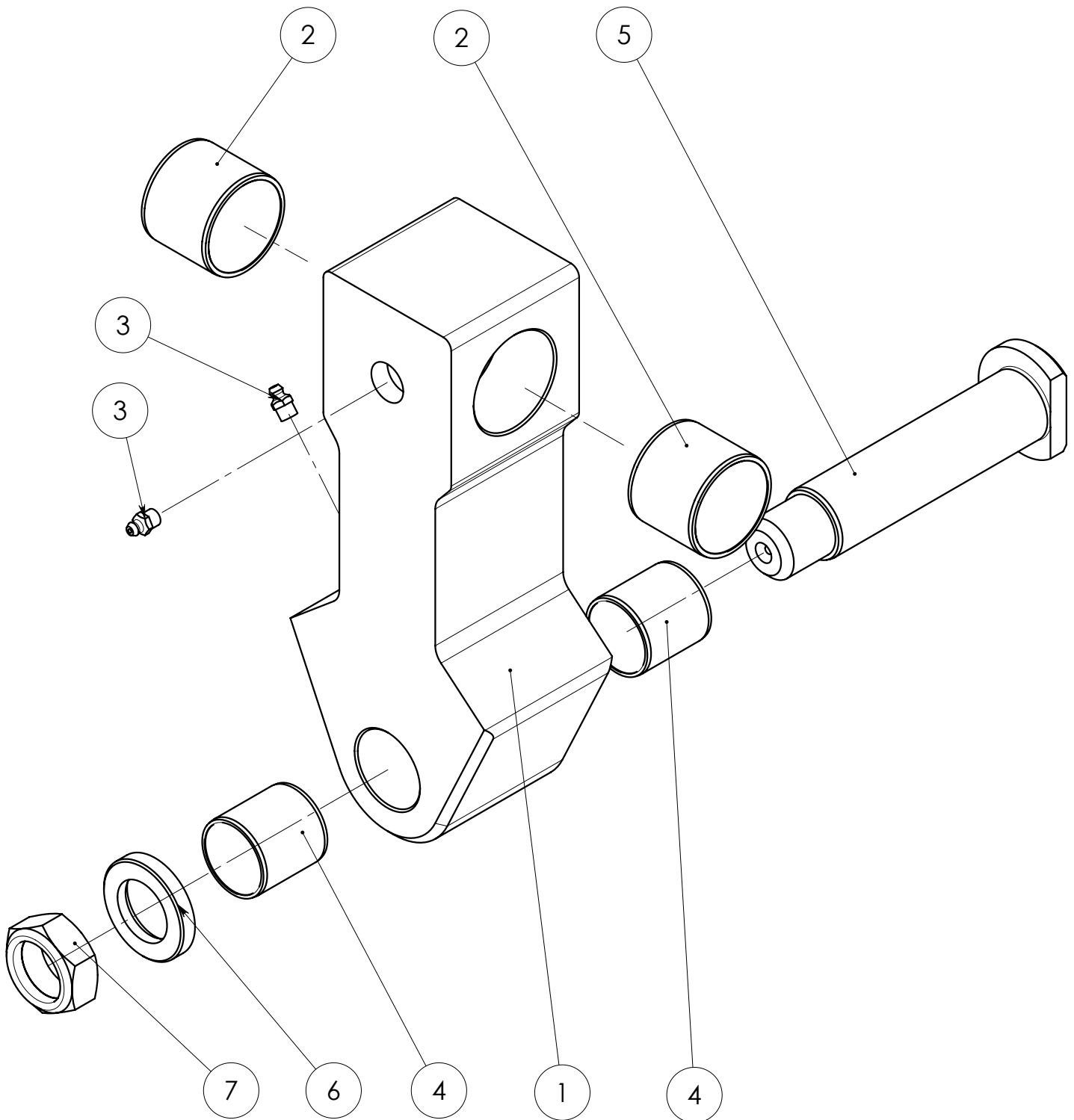

SPARE PART LIST

Item code	90012142	Revision	-
Title	RIIPUKE	Date	12.04.2005
Specification			

Pos	Item code	Title	Specification	Dimensions	Pc	Amount	Unit	Nto Weight
1	90011322	RIIPUKE LÄNK LINK GELENK		L=289	1			11.79
2	3100215	LAAKERI LAGER BEARING LAGER	WB 802 4540		2			0.12
3	3050003	RASVANIPPA SMÖRJNIPPEL GREASE NIPPLE SCHMIERNIPPEL	M8X1,25 DIN 71412		2			0
4	3100196	LAAKERI LAGER BEARING LAGER	WB 802 3540		2			0.07
5	90013110	AKSELI AXEL AXLE ACHSE	35-172	L=207	1			1.32
6	90013659	ALUSLEVY BRICKA WASHER UNTERLEGSCHIBE	50/31-8	65x65	1			0.07
7	3020144	MUTTERI MUTTER NUT MUTTER	KM6 M30X1,5 ZN NYLOC		1			

3091211

SUODATIN

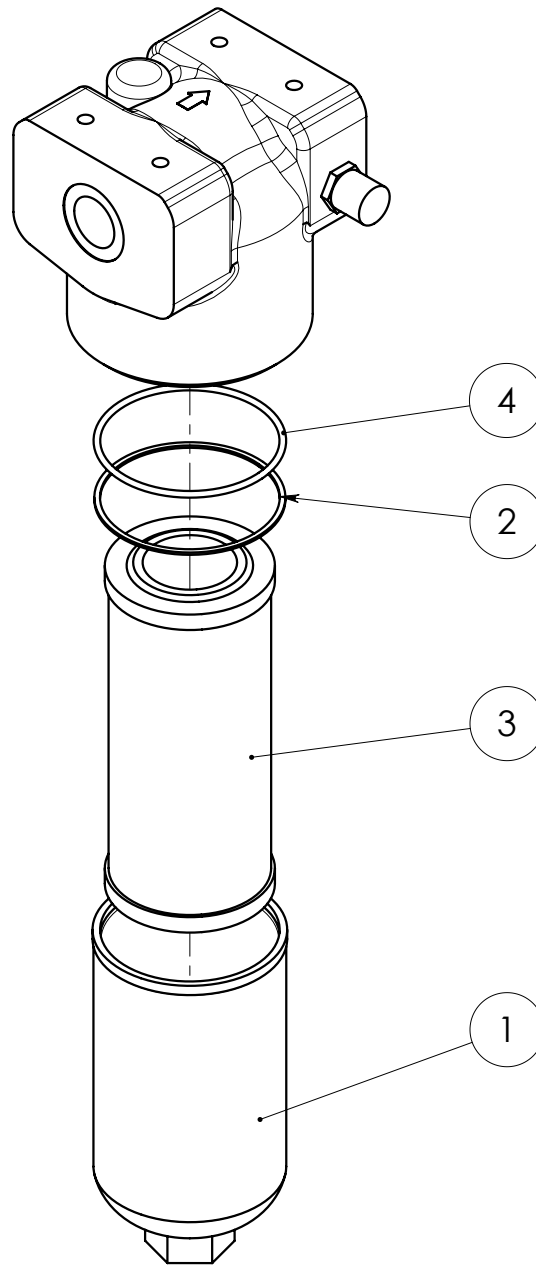



SPARE PART LIST

Item code	3091211	Revision	-
Title	SUODATIN	Date	29.05.2008
Specification	70T220QBPKG161S01		

Pos	Item code	Title	Specification	Dimensions	Pc	Amount	Unit	Nto Weight
1	3090979	SUODATIN FILTER FILTER FILTER	FF7006		1			
2	3110707	TIIVISTE TÄTNING SEAL DICHTUNG	TR 95.1X101.1X1.5 PO-01		1			0
3	3090885	SUODATIN FILTER FILTER FILTER	FC7006.Q020.BK		1			
4	3110706	TIIVISTE TÄTNING SEAL DICHTUNG	O 94.84X3.53 90SH		1			0.02

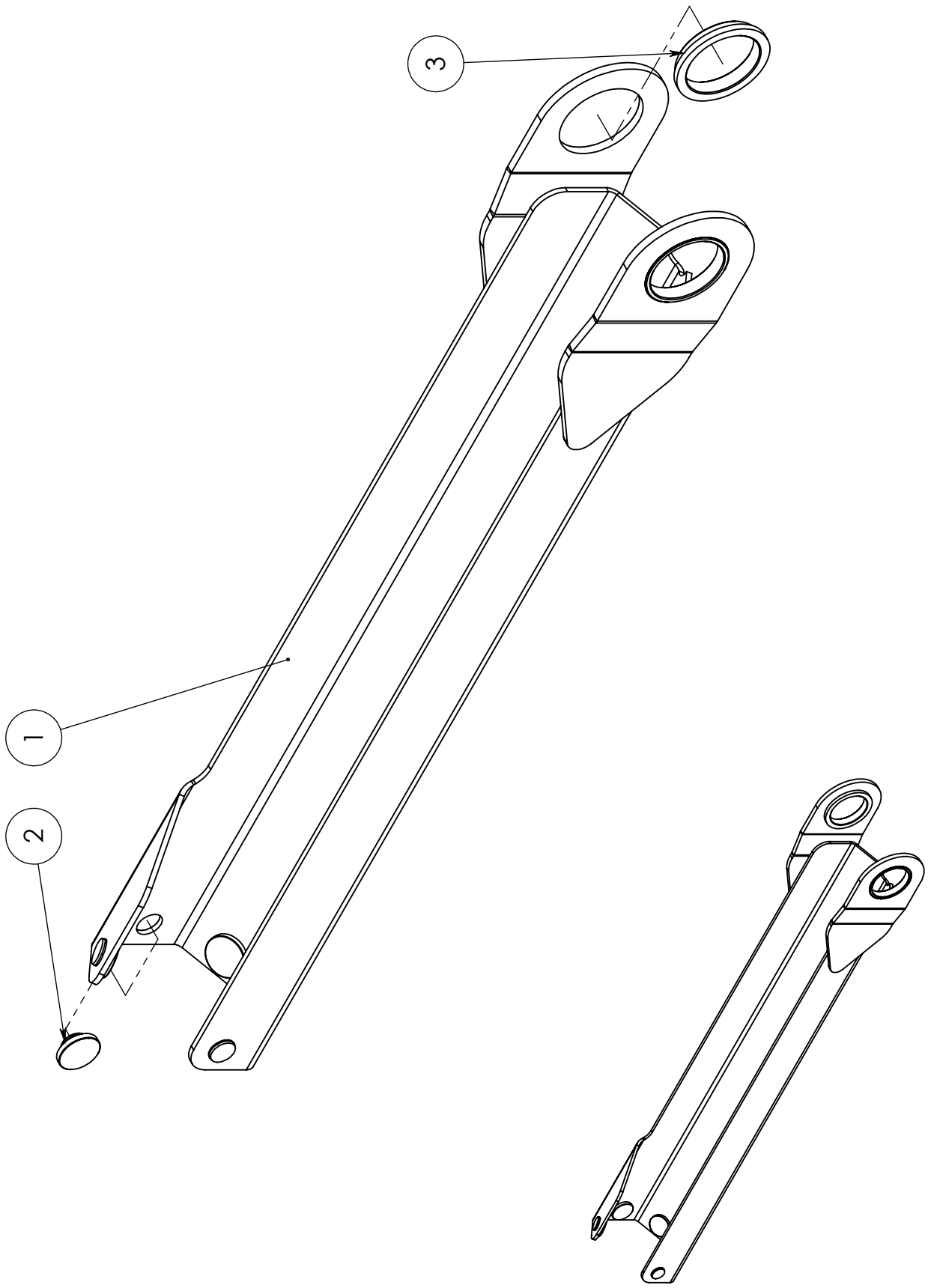

90022768 SUOJA

VARAOSAT \ RESERVDELAR \ SPARE PARTS \ ERSATZTEIL



SPARE PART LIST

Item code	90022768	Revision	-
Title	COVER	Date	12.09.2008
Specification	KESLA 2009L NOSTOS. SUOJA		

Pos	Item code	Title	Specification	Dimensions	Pc	Amount	Unit	Ntto Weight
1	90022766	COVER	NOSTOSYL HITS		1			15.84
2	90013832	GLIDE PAD	40-14	L=16	5			0.01
3	90022769	SLEEVE	90/71-15	L=15	2			0.02

90022522

VARUSTELU

KIINNITYSPULTIT

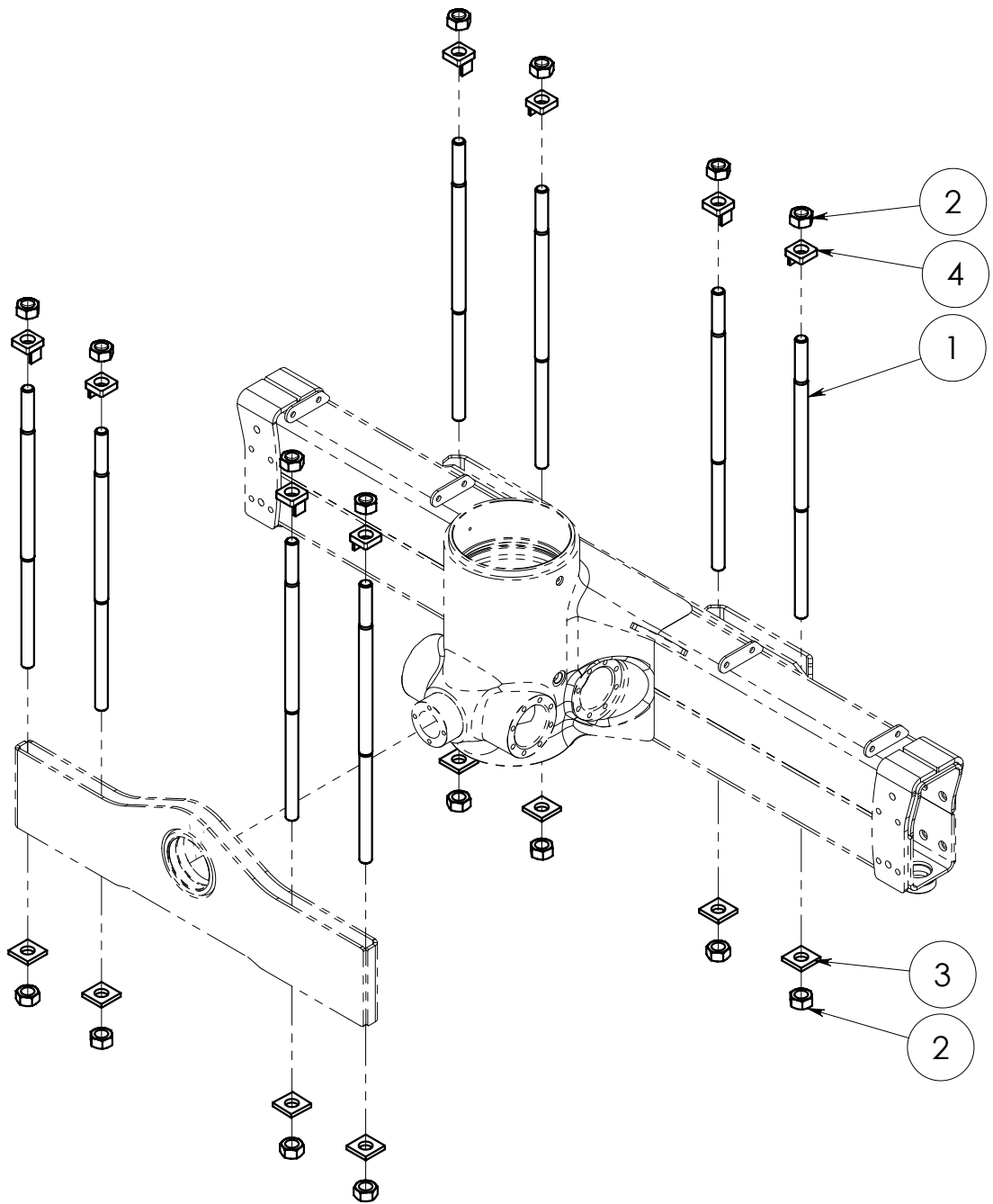

KIRISTYSMOMENTTI 1200Nm (122 kpm)



SPARE PART LIST

Item code	90022522	Revision	-
Title	VARUSTELU	Date	30.04.2008
Specification	KIINNITYSPULTIT		KESLA 2009L, 2010L

Pos	Item code	Title	Specification	Dimensions	Pc	Amount	Unit	Nto Weight
1	90022238	RUUVI SKRUV SCREW SCHRAUBE	M30X2-750	L=750	8			3.87
2	3020170	MUTTERI MUTTER NUT MUTTER	KM 30 X 2 ZN DIN 934		16			0
3	90014010	ALUSLEVY BRICKA WASHER UNTERLEGSCHEIBE	60X60/31-10	L=60	8			0.22
4	90013054	ALUSLEVY BRICKA WASHER UNTERLEGSCHEIBE	M30-16		8			0.28
1-4	90022521	RUUVI SKRUV SCREW SCHRAUBE	SARJA M30X2-750		1			24,8

